



**S**AFETY **T**ESTING **V**ALUE **A**SSURANCE

Scaffold • Shoring • Tube & Clamp • System  
MANUFACTURING & SALES



2022-2023  
**PRODUCT  
CATALOG**



19902 Hufsmith-Kohrville Rd • Tomball, TX 77375  
877-890-8490 | 281-890-6150 (FAX)  
[www.STVAonline.com](http://www.STVAonline.com) | e-mail: [order@stvaonline.com](mailto:order@stvaonline.com)



# BUY DIRECT FROM THE MANUFACTURER

*Your Satisfaction  
is our #1 Goal*



*All of our  
scaffolding  
goes through **FIVE**  
rigorous **quality control**  
checks to ensure all scaffold  
industry standards are met.*

- US Owned, US Engineered
- Competitive Prices
- Safe Products - By US Safety Standards
- Cutting Edge Product Development

All STVA Welders are certified to AWS D1.1 structural welding fabrication code - WPS, and welder certs can be supplied upon request. US Certificate of Insurance Available Upon Request.

*Call today for a **FREE** specialized quote:*

## **877-890-8490**

# TABLE OF CONTENTS

S-Style Walk-Thru Frames .....	6	Mortar Tubs.....	25
S-Style Mason Frames.....	7	Mortar Stands.....	25
W-Style Walk-Thru Frames.....	8	Veneer Jacks.....	25
W-Style Mason Frames.....	9	Multipurpose/Interior Scaffold .....	26
V-Style Walk-Thru Frames .....	10	Tube and Clamp Scaffold .....	27
V-Style Mason Frames .....	11	Scaffold Clamps.....	27
BJ-Style Walk-Thru Frames.....	12	H.L. 10K Shoring Frames .....	28
Coupling Pins & Connectors.....	13	25k Shoring Frames.....	29
Clips & Pins .....	13	10-25k Shoring Accessories.....	30
Accessories .....	14	10k Nominal Range Post Shores .....	31
Angle Iron Cross Braces .....	15	25k Nominal Range Post Shores .....	31
Tube Cross Braces.....	15	10-25k Shoring Accessories.....	32-33
Diagonal Goosers.....	15	25k Shoring Accessories .....	34
Tube Straddle Braces.....	15	Sidewalk Bridging.....	35
Locks .....	16	Back Order Products.....	36
Locking Casters.....	16	Shoring Extensions & Screw Jacks .....	36
Base Plates .....	16	Tube Cross Braces .....	36
Outrigger.....	17	Misc. Shoring Accessories .....	36
Brackets .....	17	SX Shoring Frames.....	37
Wall Ties.....	17	Misc. Products .....	38-39
Internal Stair Units .....	18	Angle Iron Cross Braces.....	39
Ladders.....	19	System Scaffold Equipment.....	40
Ladder Brackets .....	19		
Panels .....	19		
Guard Rail Panels & Gates .....	20		
Guard Rails.....	20		
Planks & Decking .....	21		
Guard Rail Posts.....	22		
Putlogs.....	23		
Scaffold Tags.....	23		
Storage & Shipping Rack & Basket.....	23		
Screw Jacks.....	24		
Concrete Forming Accessories .....	24		
Hoist Arm & Well Wheels.....	25		
Folding A-Frames .....	25		
Stanchions.....	25		

# OUR QUALITY POLICY

*Your Satisfaction  
is our #1 Goal*



*U.S. Insured*

*Largest Inventory*

*International Shipping*

*Domestic Shipping*

*ANSI/SAIA Tested*

*OSHA Certified Staff*

# QUALITY STATEMENT

STVA Scaffold is absolutely committed to meeting and exceeding our customer's quality and service expectations. I personally affirm this commitment. I am leading the effort to establish a quality scaffold manufacturing system, which will assure our customers receive the best quality products we can provide. We are committing ourselves to a strategy of continuous improvement, relentlessly seeking to learn the expectations of our customers, and striving to meet and exceed those expectations of our customers with this quality system.

We intend for these efforts to help us meet the following goals:

- Maintain our position at the cutting edge of scaffolding product development and technology.
- Maintain our reputation for quality scaffold products, service, and industry responsibility.

The entire STVA Scaffold Division must adhere to the Panaseas International, Inc. quality policy as well as the directives of the quality manual. I am actively involved in building this exciting new effort as a member of the quality assurance team as well as following through with the execution of various responsibilities. We treat each and every customer how we would like to be treated. We thank you for your business.

Sincerely,

**SANDRA K. CZICHOS**

CEO Panaseas International, Inc.

**WHEN YOU  
ARE SATISFIED,  
WE ARE  
SATISFIED!**



## ABOUT OUR COMPANY

STVA Scaffold is completely owned by a US (Houston) corporation. Our CEO has over fifty years of experience in owning and operating a business. It has been our company's policy to do business the old-fashioned way, on a hand shake. We carry US insurance covering all products we sell. Our factory and products are designed and built to US standards by US engineers. STVA Scaffold manufactures most of the products depicted in this catalog.

We pride ourselves in providing a quality product at a great price. Panaseas International, Inc., the parent company of STVA Scaffold, has been in business for 18 years manufacturing a wide range of products. As a manufacturer, we are able to explore other products that are not listed in this catalog. Using our expansive shipping capabilities, STVA Scaffold is able to distribute our products worldwide.

We expanded our plant facilities in 2015. Our new state-of-the-art manufacturing facility is more than capable of meeting the production needs of any size job. This new manufacturing facility in Rizhao, China is totally committed to maintaining production of metal products for our scaffold and shoring division. The new plant consists of two 70,700 square foot buildings for a total of 141,400 square feet under cover on 15 acres, an office building with 6,000 square feet, as well as a dormitory, which houses 100 workers with a dining room and kitchen facility. The entire plant is operational 7 days a week, 24 hours a day. This gives us the capability to provide better overall control of our scaffold quality.

We have a competent staff of engineers and technicians, as well as a knowledgeable sales force. We will assure you the highest quality, safety, and service available. We meet or exceed the highest industry standards with all of our scaffold, system, and shoring products. If you have any questions or comments, please do not hesitate to call or e-mail our sales staff.

*STVA Scaffold is not certified to erect scaffolding, design false works structures or construct scaffolding units past the production phases. STVA Scaffold is not responsible for improper use of its scaffolding products. End users should consult an engineer about proper specifications for structures. As a manufacturer, STVA's liability is limited to our manufactured products.*



# S-STYLE

Walk-Thru Frames

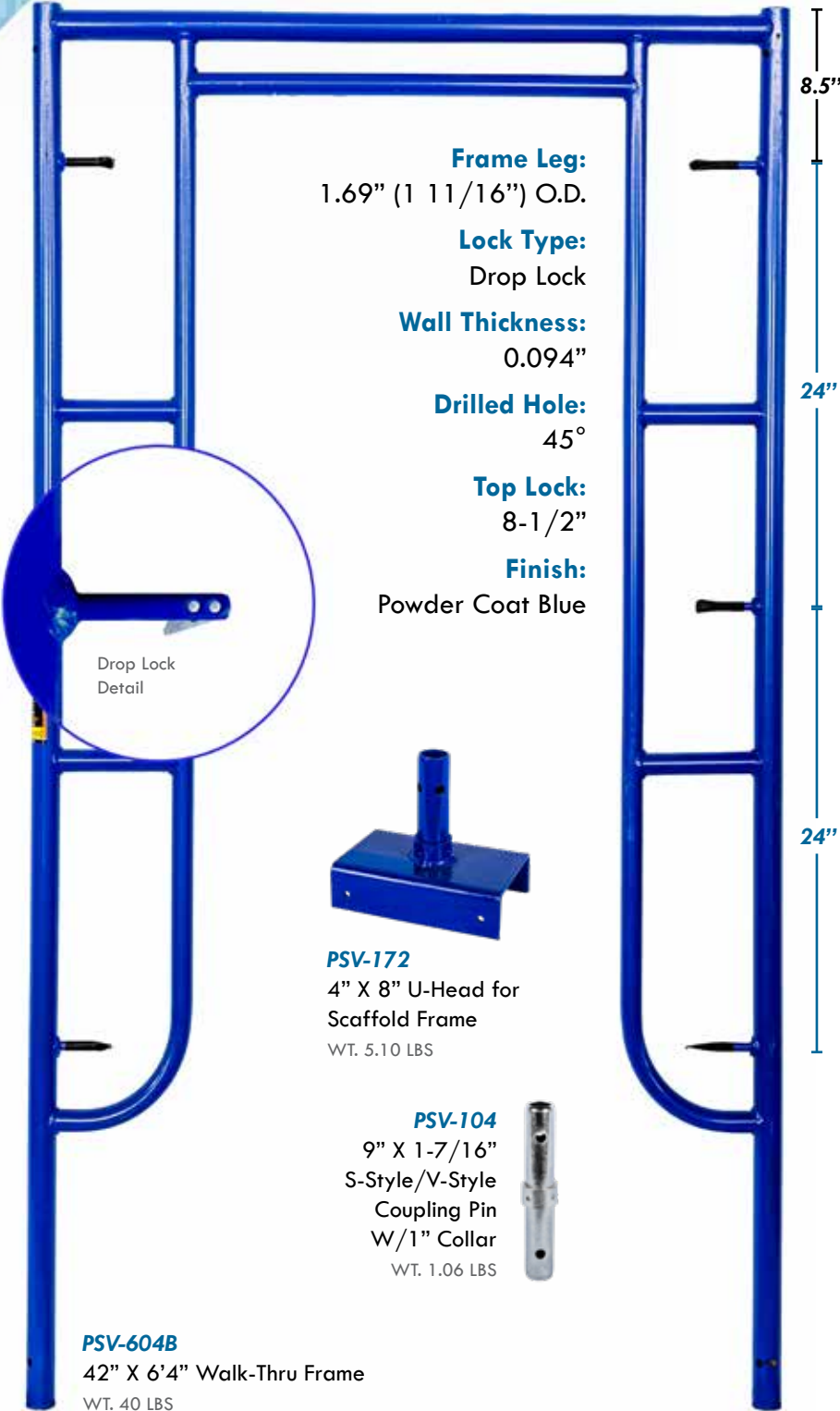

**Frame Leg:**  
1.69" (1 11/16") O.D.

**Lock Type:**  
Drop Lock

**Wall Thickness:**  
0.094"

**Drilled Hole:**  
45°

**Top Lock:**  
8-1/2"

**Finish:**  
Powder Coat Blue



Drop Lock Detail



**PSV-172**  
4" X 8" U-Head for Scaffold Frame  
WT. 5.10 LBS



**PSV-104**  
9" X 1-7/16"  
S-Style/V-Style Coupling Pin  
W/1" Collar  
WT. 1.06 LBS

**PSV-604B**  
42" X 6'4" Walk-Thru Frame  
WT. 40 LBS

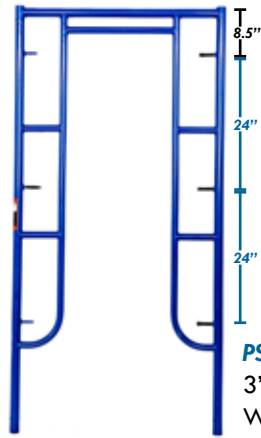

**PSV-601B**  
3' X 6'4" S-Style Walk-Thru Frame  
WT. 41.40 LBS

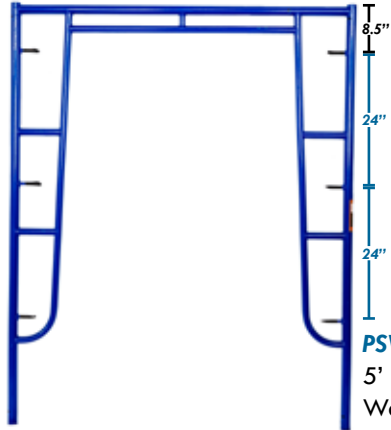

**PSV-610B**  
5' X 6'4" S-Style Walk-Thru Frame  
WT. 46.60 LBS

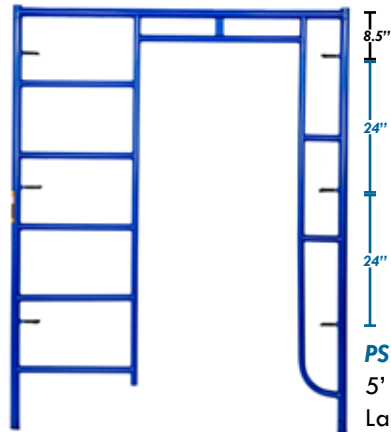

**PSV-620B**  
5' X 6'4" S-Style Ladder & Walk-Thru Frame  
WT. 52.40 LBS

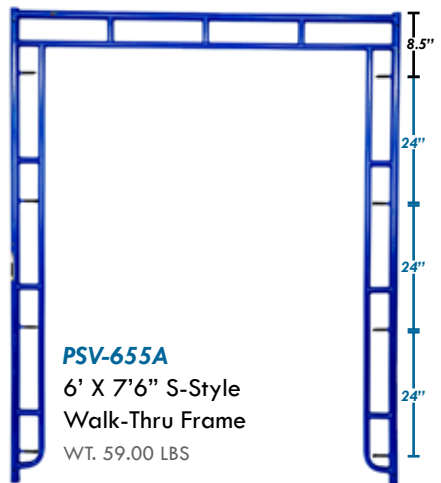

**PSV-655A**  
6' X 7'6" S-Style Walk-Thru Frame  
WT. 59.00 LBS



# S-STYLE

Mason Frames



**PSV-403B8**  
3' X 3' S-Style  
Single Ladder

WT. 22.40 LBS

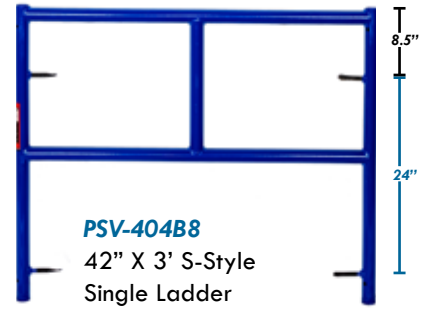

**PSV-404B8**  
42" X 3' S-Style  
Single Ladder

WT. 22.20 LBS

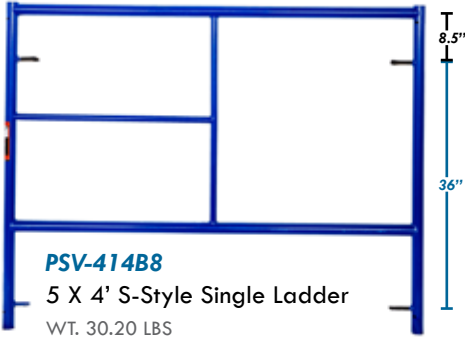

**PSV-414B8**  
5 X 4' S-Style Single Ladder

WT. 30.20 LBS

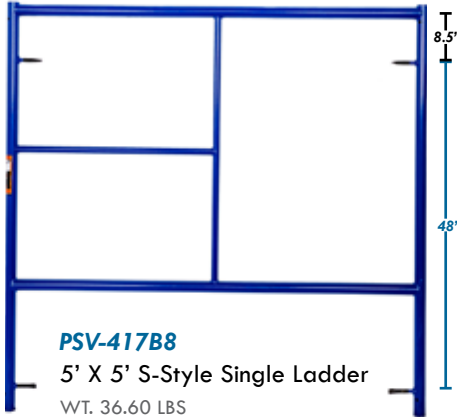

**PSV-417B8**  
5' X 5' S-Style Single Ladder

WT. 36.60 LBS

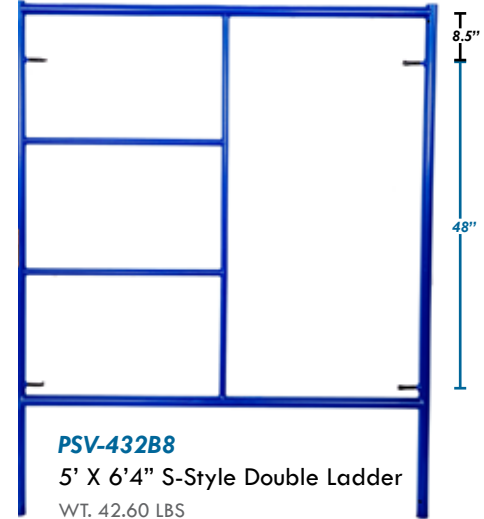

**PSV-432B8**  
5' X 6'4" S-Style Double Ladder

WT. 42.60 LBS

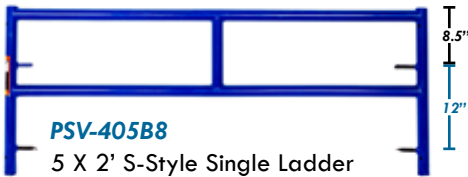

**PSV-405B8**  
5 X 2' S-Style Single Ladder

WT. 23.40 LBS



**PSV-411B8**  
5 X 3' S-Style Single Ladder

WT. 27.40 LBS

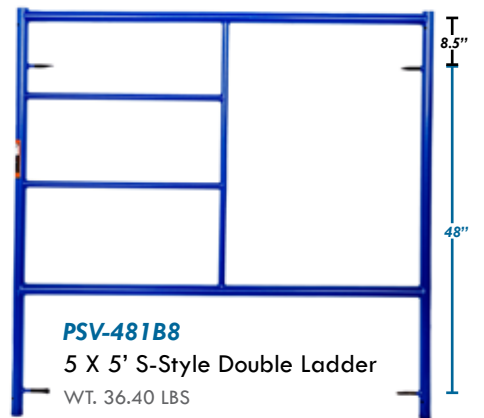

**PSV-481B8**  
5 X 5' S-Style Double Ladder

WT. 36.40 LBS

**PSV-493**  
2' X 6'4" S-Style  
Single Ladder (8.5")  
WT. 22.40 LBS

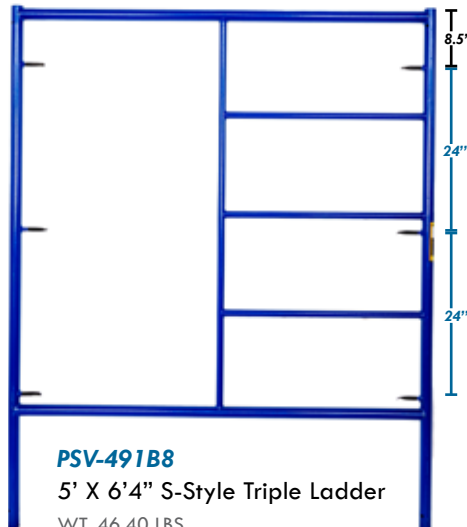
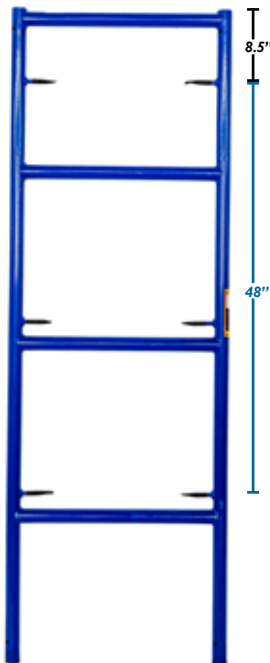

**PSV-491B8**  
5' X 6'4" S-Style Triple Ladder

WT. 46.40 LBS

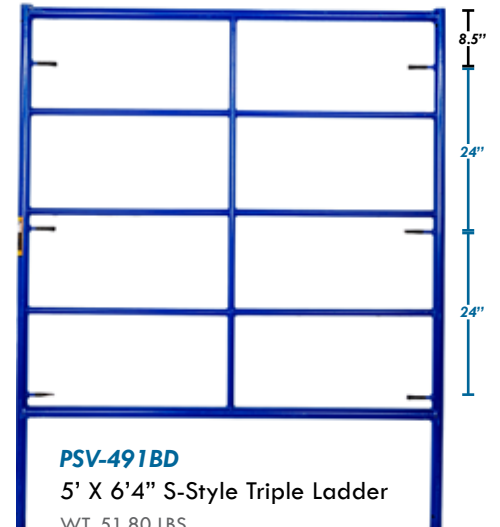

**PSV-491BD**  
5' X 6'4" S-Style Triple Ladder

WT. 51.80 LBS



# W-STYLE

## Walk-Thru Frames

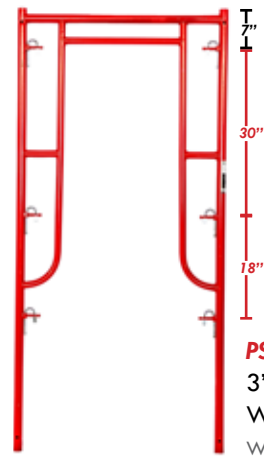

**PSV-635AC**  
3' X 6'7" W-Style  
Walk-Thru Frame (2 Rung)  
WT. 37.75 LBS

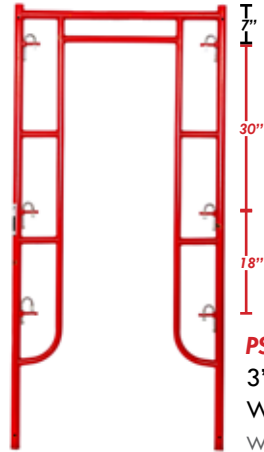

**PSV-636AC**  
3' X 6'7" W-Style  
Walk-Thru Frame (3 Rung)  
WT. 42.35 LBS

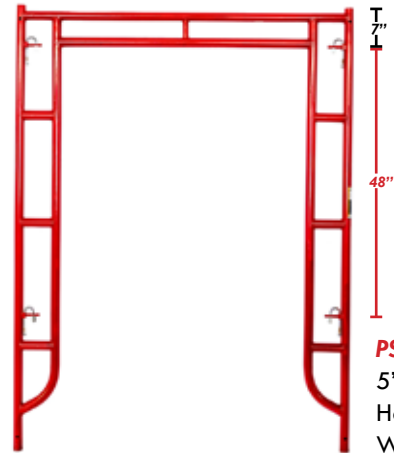

**PSV-632AC**  
5' X 6'7" W-Style  
Heavy Duty  
Walk-Thru Frame  
WT. 37.75 LBS

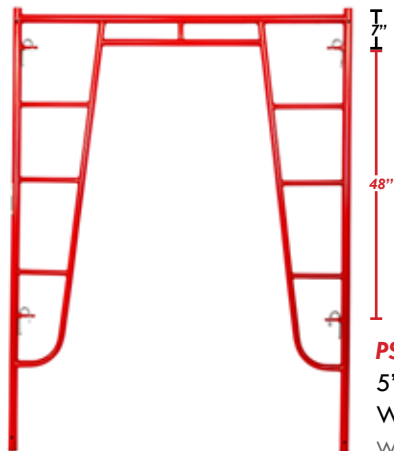

**PSV-634AC**  
5' X 6'7" W-Style  
Walk-Thru Frame  
WT. 45.56 LBS

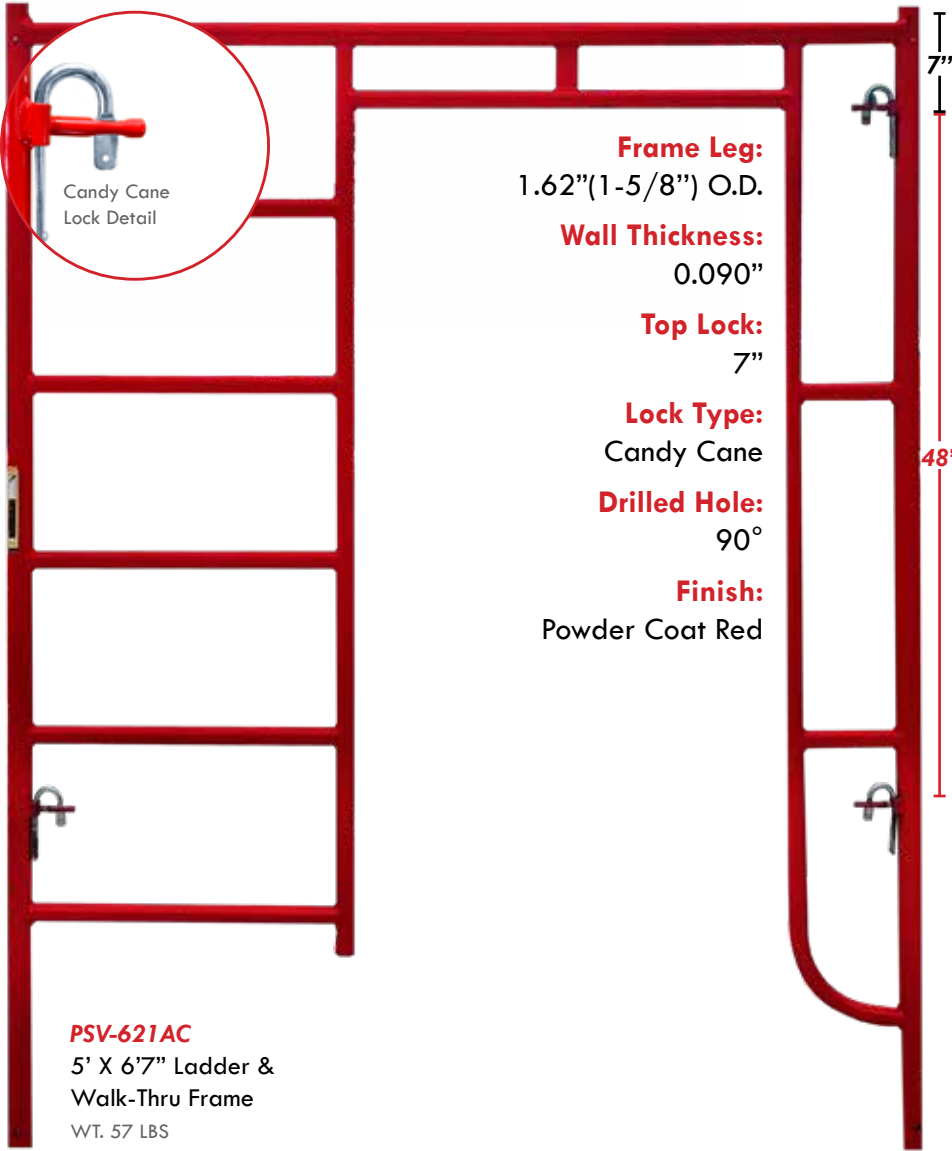

Candy Cane  
Lock Detail

**Frame Leg:**  
1.62"(1-5/8") O.D.

**Wall Thickness:**  
0.090"

**Top Lock:**  
7"

**Lock Type:**  
Candy Cane

**Drilled Hole:**  
90°

**Finish:**  
Powder Coat Red

**PSV-621AC**  
5' X 6'7" Ladder &  
Walk-Thru Frame  
WT. 57 LBS

**PSV-100**  
7" 1-3/8" W-Style  
Coupling Pin  
W/1/8" Collar  
WT. 0.79 LBS



**PSV-103**  
7" 1-3/8" W-Style  
Coupling Pin  
W/No Collar  
WT. 0.59 LBS







# W-STYLE

Mason Frames

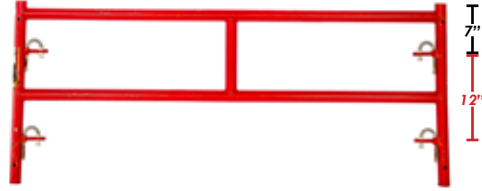

**PSV-408A**  
5' X 2'1" W-Style  
Single Ladder  
WT. 25.01 LBS

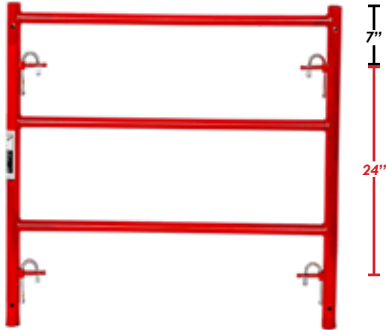

**PSV-407A**  
3' X 3'1" W-Style  
Single Ladder  
WT. 21.80 LBS

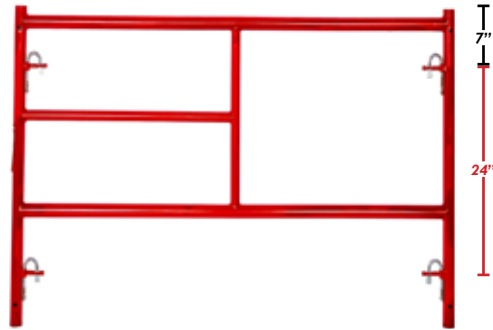

**PSV-409A**  
5' X 3'1" W-Style  
Single Ladder  
WT. 30.40 LBS

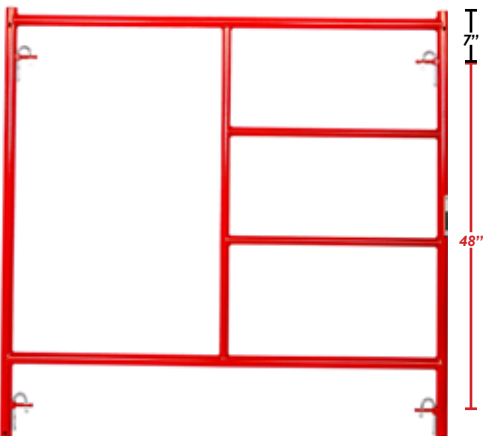

**PSV-419A**  
5' X 5'1" W-Style  
Double Ladder  
WT. 41.20 LBS

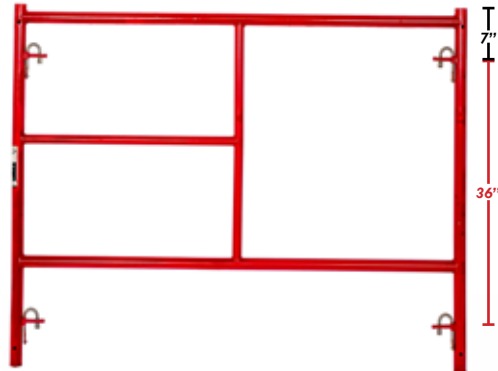

**PSV-410A**  
5' X 4'1" W-Style  
Single Ladder  
WT. 35 LBS

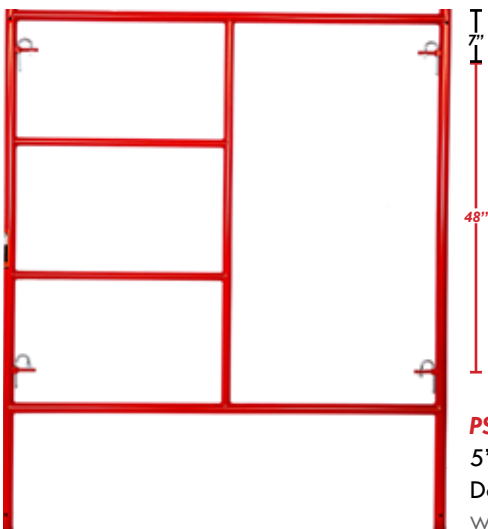

**PSV-429A**  
5' X 6'7" W-Style  
Double Ladder  
WT. 49.20 LBS



**PSV-428A**  
3' X 6'7" W-Style  
Ladder Frame  
WT. 36.06 LBS



# V-STYLE

Walk-Thru Frames

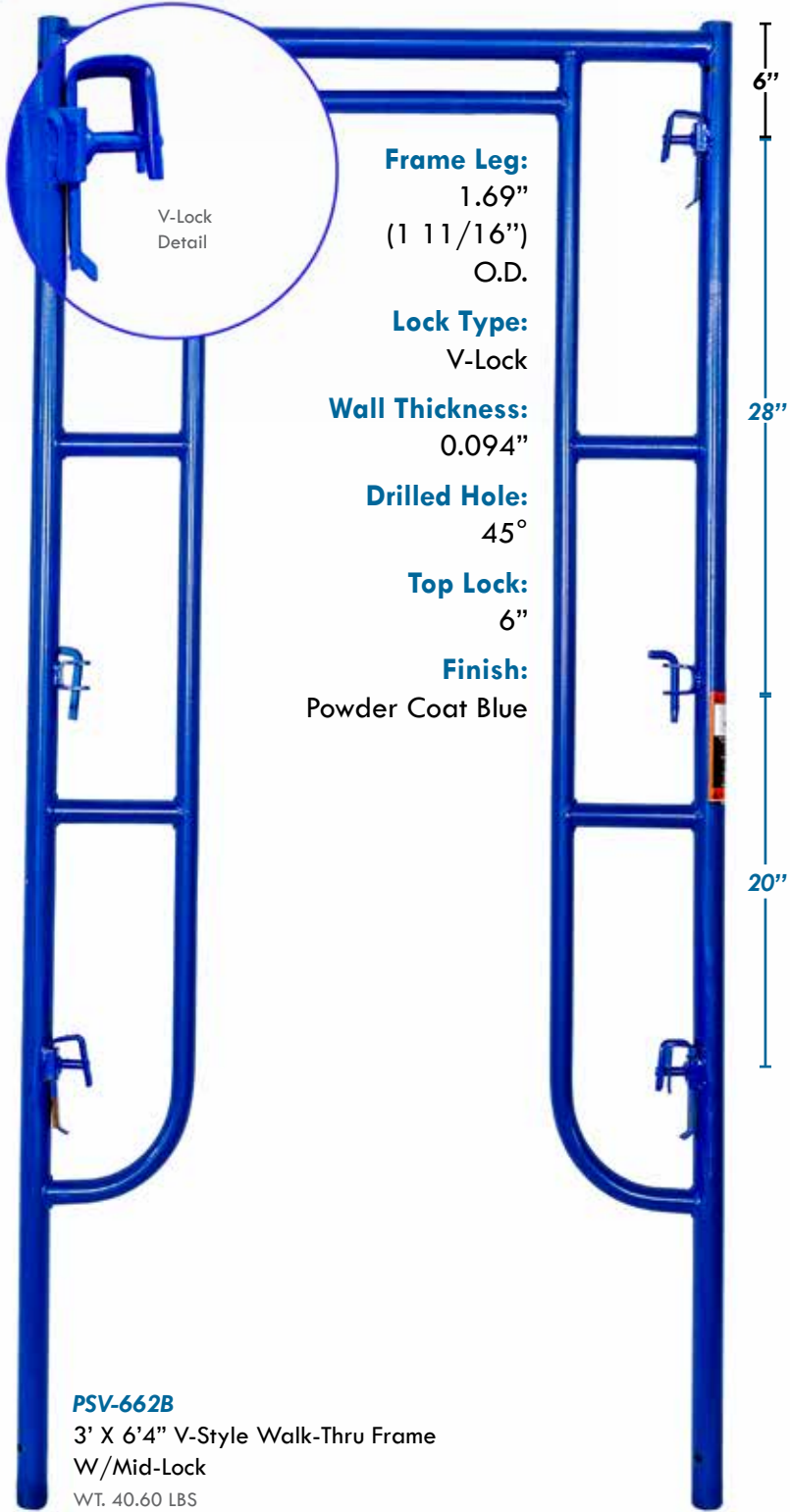

**Frame Leg:**  
1.69"  
(1 11/16")  
O.D.

**Lock Type:**  
V-Lock

**Wall Thickness:**  
0.094"

**Drilled Hole:**  
45°

**Top Lock:**  
6"

**Finish:**  
Powder Coat Blue

**PSV-662B**  
3' X 6'4" V-Style Walk-Thru Frame  
W/Mid-Lock  
WT. 40.60 LBS

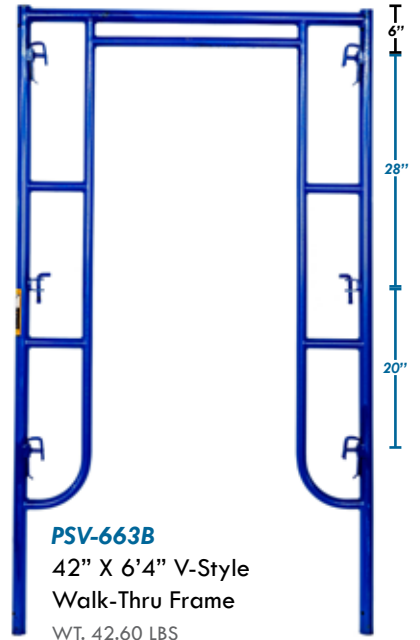

**PSV-663B**  
42" X 6'4" V-Style  
Walk-Thru Frame  
WT. 42.60 LBS

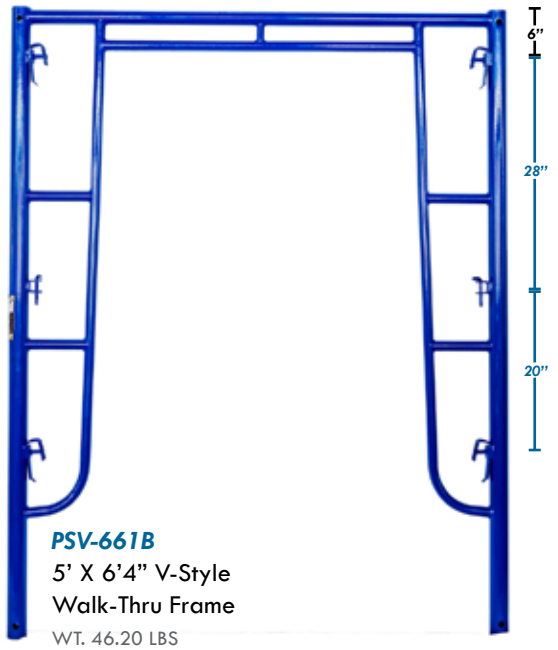

**PSV-661B**  
5' X 6'4" V-Style  
Walk-Thru Frame  
WT. 46.20 LBS



**PSV-104**  
9" X 1-7/16" S/V  
Coupling Pin  
W/1" Collar  
WT. 1.06 LBS



# V-STYLE

Mason Frames

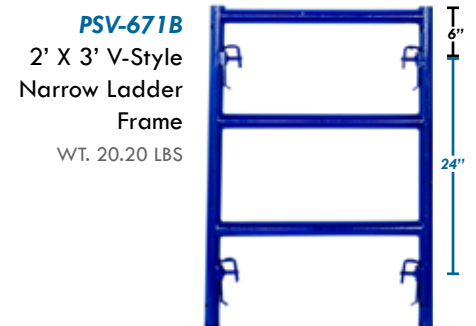
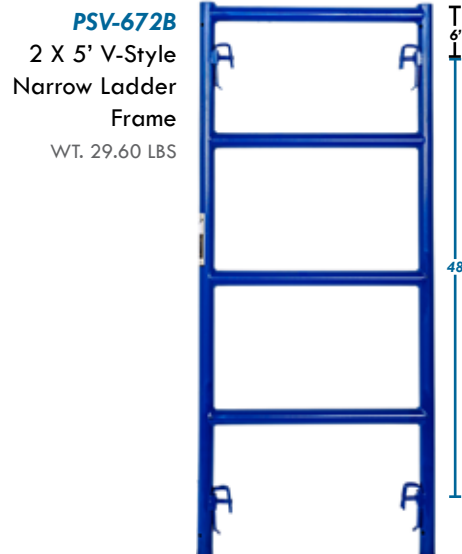
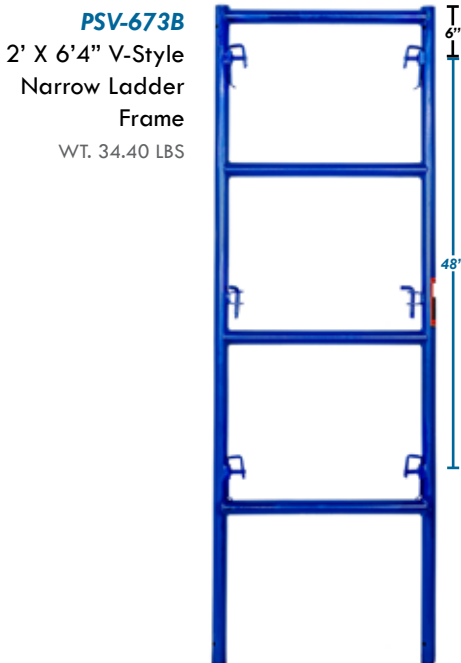
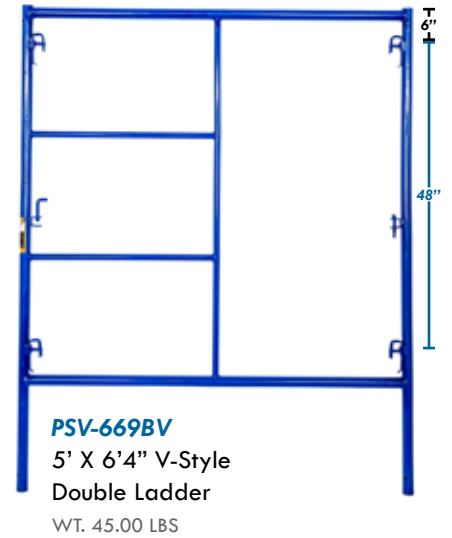
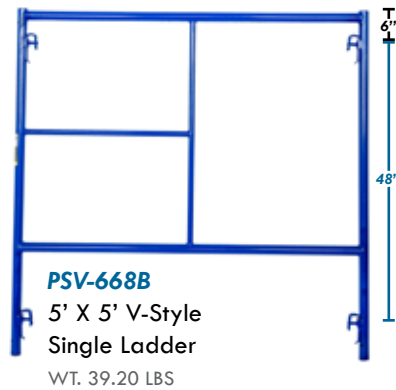
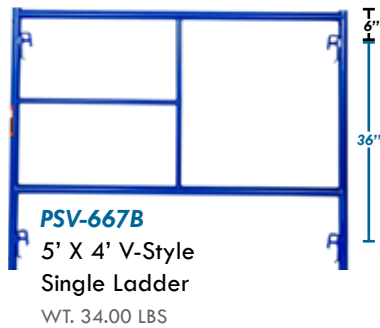
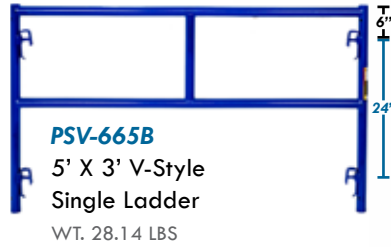
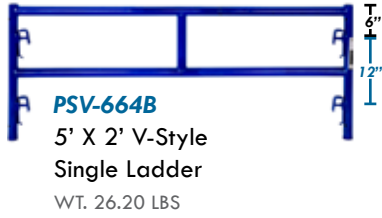



# BJ-STYLE

## Walk-Thru Frames



11.75"  
27.75"  
27.75"

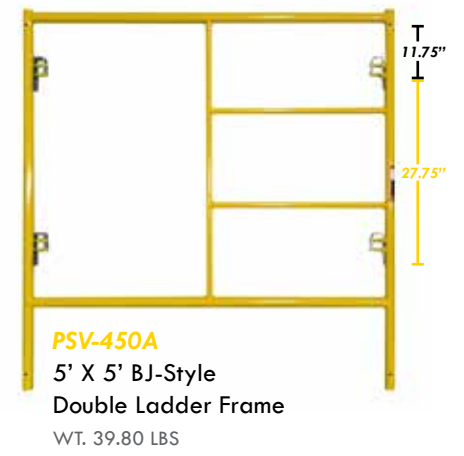
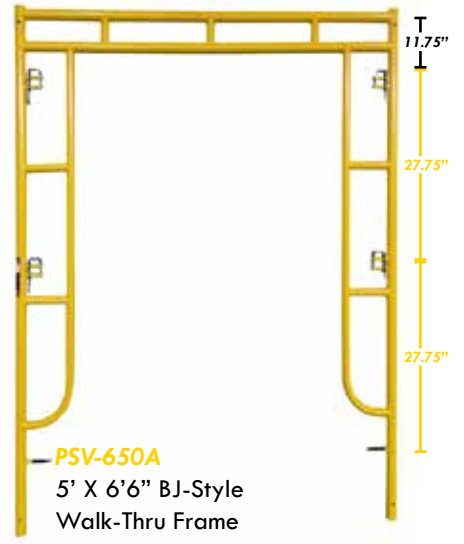



# COUPLING

*Pins & Connectors*



**PSV-100**  
7" 1-3/8" W-Style  
Coupling Pin  
W/ 1/8" Collar  
WT. 0.79 LBS



**PSV-101**  
9" X 1-1/4" BJ-Style  
Coupling Pin  
W/ 1" Collar  
WT. 0.83 LBS



**PSV-102**  
1-7/8" H.L. Shoring  
Connector  
WT. 0.96 LBS



**PSV-102B**  
1-7/8" Universal  
H.L. Shoring  
Connector  
WT. 1.12 LBS



**PSV-103**  
7" X 1-3/8" W-Style &  
BJ-Style (STVA) Coupling  
Pin W/ No Collar  
WT. 0.59 LBS



**PSV-104**  
9" X 1-7/16" S-Style  
Coupling Pin  
W/ 1" Collar  
WT. 1.06 LBS



**PSV-105A**  
1-3/8" X 1-7/8"  
Shoring To W-Style  
Coupling Pin  
WT. 1.17 LBS



**PSV-105B**  
1-7/16" X 1-7/8"  
Shoring To S-Style  
Coupling Pin  
WT. 1.17 LBS



**PSV-107**  
9" X 1-3/8" BJ-Style  
(STVA) Coupling Pin  
W/ 1" Collar  
WT. 0.87 LBS



**PSV-108**  
7" BJ-Style  
(Original) Coupling Pin  
W/ No Collar  
WT. 0.64 LBS

# CLIPS

*& pins*



**PSV-111** Span Pin  
WT. 0.10 LBS

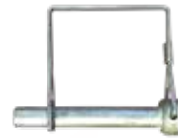

**PSV-111S** Square Span Pin  
WT. 0.12 LBS



**PSV-112** 3-1/2" Toggle Pin  
WT. 0.14 LBS



**PSV-112S** 2-1/2" Toggle Pin  
WT. 0.10 LBS



**PSV-113** Spring Clip  
WT. 0.05 LBS



**PSV-114** Pig Tail Pin  
WT. 0.21 LBS



**PSV-115** Roll Pin  
WT. 0.04 LBS

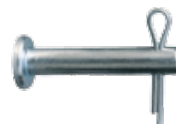

**PSV-118** Rivet Pin WT. 0.07 LBS  
**PSV-119** Cotter Pin WT. 0.01 LBS



**PSV-129** J-Pin  
WT. 0.56 LBS



# ACCESSORIES

*From Cross Braces  
to Outriggers  
& More*



## **AERIAL TOOL & Bucket Tray**

**PSV-5002-00-BO**

Aerial Tool & Bucket Tray

WT. 12.0 LBS



## **STVA** ANGLE IRON *Cross Braces*

- PSV-350** 4' X 3' X 4' Angle Iron Cross Brace WT. 9.90 LBS
- PSV-351** 5' X 3' X 4' Angle Iron Cross Brace WT. 12.00 LBS
- PSV-352** 6' X 3' X 4' Angle Iron Cross Brace WT. 12.45 LBS
- PSV-353** 7' X 3' X 4' Angle Iron Cross Brace WT. 13.86 LBS
- PSV-354** 8' X 3' X 4' Angle Iron Cross Brace WT. 15.36 LBS
- PSV-365** 10' X 3' X 4' Angle Iron Cross Brace WT. 22.40 LBS

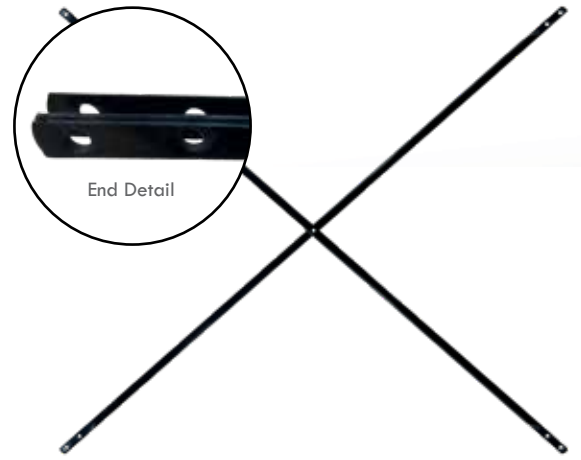

## **STVA** TUBE *Cross Braces*

- PSV-300** 5' X 2' Tube Cross Brace WT. 8.00 LBS
- PSV-301** 7' X 2' Tube Cross Brace WT. 11.20 LBS
- PSV-302** 7' X 3' Tube Cross Brace WT. 11.20 LBS
- PSV-303** 7' X 4' Tube Cross Brace WT. 11.40 LBS
- PSV-304** 7' X 3' X 4' Tube Cross Brace WT. 11.00 LBS
- PSV-305** 10' X 4' Tube Cross Brace WT. 14.80 LBS
- PSV-306** 10' X 3' X 4' Tube Cross Brace WT. 14.60 LBS
- PSV-307** 10' X 2' Tube Cross Brace WT. 14.20 LBS
- PSV-308** 10' X 3' Tube Cross Brace WT. 15.00 LBS
- PSV-309** 7' X 1' Tube Cross Brace WT. 10.20 LBS
- PSV-311** 7' X 42" Tube Cross Brace WT. 11.40 LBS
- PSV-312** 5' X 4' Tube Cross Brace WT. 9.30 LBS
- PSV-313** 6' X 4' Tube Cross Brace WT. 10.00 LBS
- PSV-314** 8' X 2' Tube Cross Brace WT. 11.60 LBS
- PSV-316** 8' X 3' X 4' Tube Cross Brace WT. 12.60 LBS
- PSV-317** 7' X 27-3/4" Tube Cross Brace WT. 11.80 LBS
- PSV-319** 10' X 27-3/4" Tube Cross Brace WT. 8.60 LBS
- PSV-320** 10' X 1' Tube Cross Brace WT. 13.60 LBS
- PSV-321** 4' X 4' Tube Cross Brace WT. 8.18 LBS
- PSV-325** 6' X 1' Tube Cross Brace WT. 8.80 LBS
- PSV-326** 6' X 2' Tube Cross Brace WT. 9.11 LBS
- PSV-329** 5' X 3' X 4' Tube Cross Brace WT. 9.42 LBS
- PSV-332** 7' X 5' Tube Cross Brace WT. 12.23 LBS
- PSV-333** 8' X 5' Tube Cross Brace WT. 13.60 LBS
- PSV-335** 4' X 3' X 4' Tube Cross Brace WT. 7.80 LBS
- PSV-339** 5' X 27-3/4" Tube Cross Brace WT. 8.07 LBS

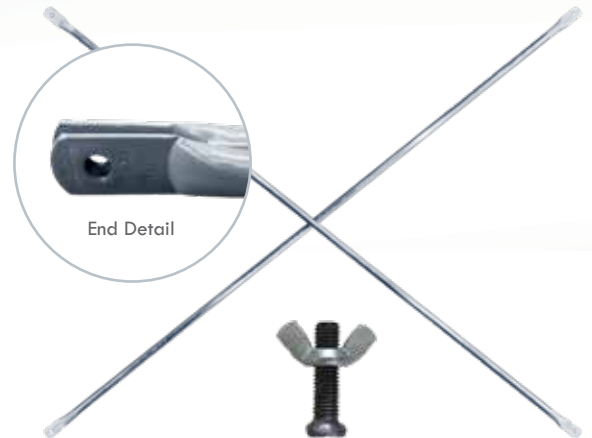

**PSV-371N** Wingnut Lock  
for Hook on Angle Iron Braces  
WT. 0.066 LBS

## **STVA** *DIAGONAL Goosers*



- PSV-1200** 7' X 5' Diagonal Goosener WT. 10.80 LBS
- PSV-1201** 10' X 5' Diagonal Goosener WT. 14.20 LBS

## **STVA** *TUBE STRADDLE Braces*



- PSV-1600**  
7' X 4' Tube Straddle Braces  
WT. 19.25 LBS
- PSV-1601**  
10' X 4' Tube Straddle Braces  
WT. 23.50 LBS



## LOCKS Replacement Parts



**PSV-120**  
Flip Lock  
WT. 0.13 LBS



**PSV-121**  
Drop Lock  
WT. 0.13 LBS



**PSV-122**  
Candy Cane Lock  
WT. 0.51 LBS



**PSV-123**  
BJ-Style C-Lock  
WT. 0.84 LBS



**PSV-124**  
V-Style Lock  
WT. 0.60 LBS



## LOCKING Casters



**PSV-150**  
8" Locking Caster  
W/ 1-3/8" Round Stem  
WT. 10.97 LBS



**PSV-151**  
5" Locking Caster  
W/ 1-1/4" Square Stem  
WT. 4.20 LBS



**PSV-151R**  
5" Locking Caster  
W/ 1-1/4" Round Stem  
WT. 3.96 LBS



## BASE Plates



**PSV-141**  
1-3/8" Stem W/BJ-Style  
5" X 5" Base Plate  
WT. 1.91 LBS



**PSV-160**  
1-7/16" Stem S/V Style  
5" X 5" Base Plate  
WT. 1.92 LBS



**PSV-146A**  
6" X 6" W-Style  
Swivel Base Plate  
90° Angle  
WT. 4.05 LBS



**PSV-146B**  
6" X 6" S-Style  
Swivel Base Plate  
45° Angle  
WT. 4.05 LBS





**STVA**  
**OUTRIGGER**

**PSV-215**  
30" Outrigger For  
Frame Scaffold  
WT. 18.80 LBS

**STVA**  
**BRACKETS**

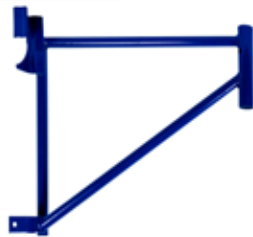

**PSV-201**  
21" Tube Side Bracket  
WT. 6.95 LBS



**PSV-203B**  
21" Saddle Tube  
Side Bracket  
WT. 10.20 LBS



**PSV-206C**  
20" Angle Iron End  
Bracket W/Clamp  
WT. 12.60 LBS



**PSV-213**  
23" Angle Iron  
Saddle Side Bracket  
WT. 11.80 LBS



**PSV-217**  
12" Tube  
Side Bracket  
WT. 5.40 LBS

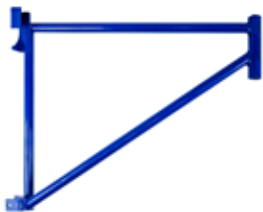

**PSV-218**  
30" Tube  
Side Bracket  
WT. 10.20 LBS



**PSV-221**  
20" - 30"  
Adjustable Saddle  
Square Tube Side Bracket  
WT. 14.61 LBS



**PSV-228AB**  
20" - 30"  
Round Tube  
Expanding Side Bracket  
WT. 14.10 LBS

**STVA**  
**WALL TIES**



**PSV-952** 3' Tube Wall Tie WT. 5.20 LBS

**PSV-953** 4' Tube Wall Tie WT. 6.80 LBS

**PSV-951** 5' Tube Wall Tie WT. 7.80 LBS

**PSV-956** 3' Tube Wall Tie W/Hooks  
WT. 6.20 LBS

**STVA**  
**INTERNAL Stair Units**



**PSV-919A & B** Stair Unit Starter Bar WT. 9.00 LBS



**PSV-917A & B** 7' Top Rail For Internal Stair Unit  
 WT. 14.20 LBS



**PSV-920A** "Red" W-Style &  
**PSV-920AYW** "Yellow" BJ-Style  
 Internal Stair Unit W/Handrails  
 (7' X 6'7" & 6'6")  
 WT. 114.80 LBS



**PSV-920B**  
 For S/V-Style Internal Stair  
 Unit W/Handrails  
 (7' X 6'4")  
 WT. 114.20 LBS



**PSV-941B**  
 For S/V-Style Internal Aluminum  
 Stair Unit W/Handrails  
 WT. 58 LBS

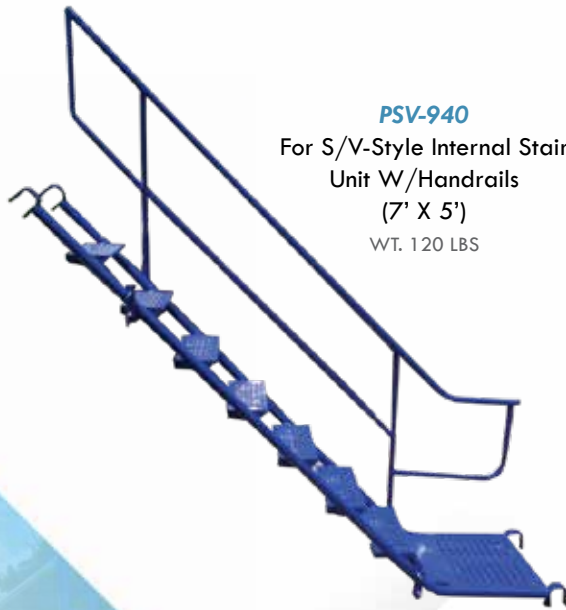

**PSV-940**  
 For S/V-Style Internal Stair  
 Unit W/Handrails  
 (7' X 5')  
 WT. 120 LBS



**PSV-920RH**  
 Rivet & Hitch Pin  
 For Stair Unit  
 WT. 0.20 LBS



**PSV-920**  
 Bolt Thumb Screw  
 For Stair Unit  
 WT. 0.10 LBS



**PSV-925B**  
 Rolling Tower Stair  
 Starter Step  
 WT. 22 LBS



**STVA**  
**LADDERS**

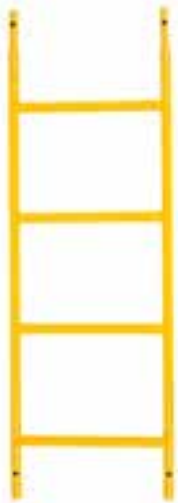

**PSV-400** 3' Ladder WT. 9.80 LBS

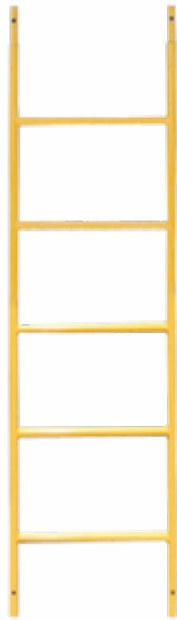

**PSV-399** 5' Ladder WT. 13.2 LBS

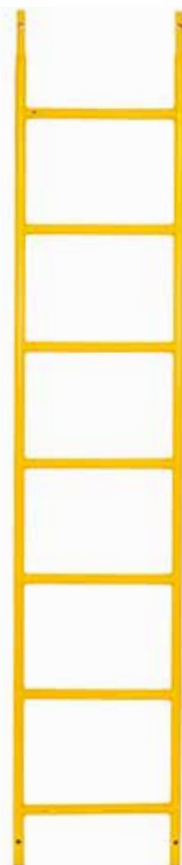

**PSV-396** 3' SAU Ladder WT. 9.44 LBS

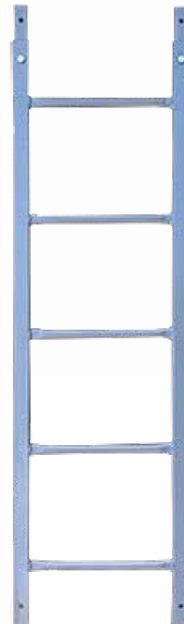

**PSV-397** 5' SAU Ladder WT. 16.17 LBS

**PSV-401** 6' Ladder WT. 16.04 LBS

**PSV-395** 6' SAU Ladder WT. 18.12 LBS

**STVA**  
**LADDER** *Brackets*



**PSV-960**  
Bolt-On Ladder Bracket  
WT. 5.6 LBS



**PSV-200**  
Ladder Bracket  
WT. 6.0 LBS



**PSV-959**  
SAU Ladder Bracket  
WT. 5.54 LBS

**STVA**  
**PANELS**

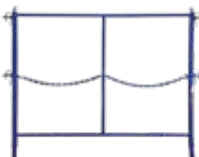

**PSV-525CC**  
S/V Access Panel  
For Mason Frame  
WT. 27.43 LBS



**PSV-524B**  
Expandable  
"P" Panel  
WT. 11.80 LBS

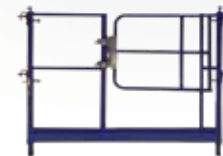

**PSV-528**  
S/V Style Access Panel  
W/Swing Gate  
WT. 63 LBS

**STVA**  
**GUARD RAIL PANELS & Gates**

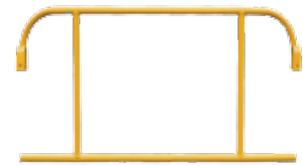

**PSV-519N**  
 3' / 42" End Panel  
 WT. 8.20 LBS



**PSV-520N** 5' End Panel  
 WT. 9.6 LBS (48.98" W X 21" H)

**PSV-520W** 5' End Panel  
 WT. 10.4 LBS (52" W X 21" H)

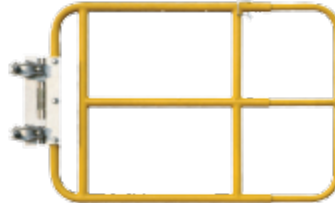

**PSV-800N**  
 3' Expandable Access Gate  
 WT. 22.40 LBS

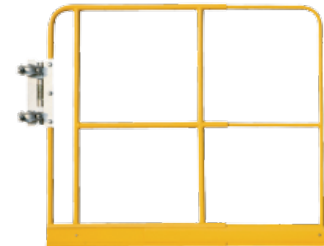

**PSV-802**  
 42" Expandable Access Gate  
 W/ Toeboard  
 WT. 32.20 LBS



**PSV-521N**  
 7' Guard Rail Side Panel  
 WT. 13.40 LBS



**PSV-522**  
 10' Guard Rail Side Panel  
 WT. 25.43 LBS



**PSV-520W632**  
 End Panel For 5' X 6' 7" W-Style  
 Walk-Thru Frame  
 WT. 10.01 LBS

**STVA**  
**GUARD Rails**



**PSV-507** 2' Guard Rail WT. 1.60 LBS

**PSV-500** 3' Guard Rail WT. 2.20 LBS

**PSV-501** 42" Guard Rail WT. 2.60 LBS

**PSV-505** 4' Guard Rail WT. 3.00 LBS

**PSV-502** 5' Guard Rail WT. 3.60 LBS

**PSV-503** 7' Guard Rail WT. 5.20 LBS

**PSV-506** 8' Guard Rail WT. 8.14 LBS

**PSV-504** 10' Guard Rail WT. 10.0 LBS



# PLANKS & Decking



**DI-65** Southern Yellow Pine Plank  
Available In The Following Sizes:

**PSV-MSR-2208** 8' Wood Plank - Blue - WT. 32.2 LBS

**PSV-MSR-2210** 10' Wood Plank - Red - WT. 39 LBS

**PSV-MSR-2212** 12' Wood Plank - Yellow - WT. 46.8 LBS

**PSV-MSR-2216** 16' Wood Plank - Green - WT. 62.4 LBS

STVA wooden planks are all color coded on the ends for easy length recognition.



**PSV-SP-03** 3' X 9" Raised Hook Steel Plank WT. 12.10 LBS

**PSV-SP-036** 3'-6" X 9" Raised Hook Steel Plank WT. 13.30 LBS

**PSV-SP-04** 4' X 9" Raised Hook Steel Plank WT. 16.50 LBS

**PSV-SP-05** 5' X 9" Raised Hook Steel Plank WT. 20.20 LBS

**PSV-SP-06** 6' X 9" Raised Hook Steel Plank WT. 24.20 LBS

**PSV-SP-07** 7' X 9" Raised Hook Steel Plank WT. 27.50 LBS

**PSV-SP-08** 8' X 9" Raised Hook Steel Plank WT. 33.00 LBS

**PSV-SP-09** 9' X 9" Raised Hook Steel Plank WT. 35.50 LBS

**PSV-SP-10** 10' X 9" Raised Hook Steel Plank WT. 38.00 LBS



**PSV-11603** 3' X 9" Flat Hook Steel Plank WT. 13.75 LBS

**PSV-1160** 3'-6" X 9" Flat Hook Steel Plank WT. 14.75 LBS

**PSV-1161** 4' X 9" Flat Hook Steel Plank WT. 17.60 LBS

**PSV-1162** 5' X 9" Flat Hook Steel Plank WT. 21.90 LBS

**PSV-1163** 6' X 9" Flat Hook Steel Plank WT. 24.90 LBS

**PSV-1164** 7' X 9" Flat Hook Steel Plank WT. 28.00 LBS

**PSV-1165** 8' X 9" Flat Hook Steel Plank WT. 34.50 LBS

**PSV-1166** 9' X 9" Flat Hook Steel Plank WT. 37.00 LBS

**PSV-1167** 10' X 9" Flat Hook Steel Plank WT. 39.60 LBS



**PSV-1108**

7' X 28" Aluminum Hatch Deck  
WT. 60 LBS

**PSV-1110**

10' X 28" Aluminum Hatch Deck  
WT. 72.8 LBS



**PSV-1115**

7' X 12" Aluminum Filler Board  
WT. 19.36 LBS

**PSV-1116**

10' X 12" Aluminum Filler Board  
WT. 26.40 LBS



**PSV-1105**

Aluminum Board  
Replacement Hooks  
WT. 0.40 LBS



**PSV-1100** 7' X 19" Alum/Plywood Deck WT. 35.10 LBS

**PSV-1104** 10' X 19" Alum/Plywood Deck WT. 51.00 LBS



**PSV-1100-02** 7' X 19" Ply/Wood Replacement Deck WT. 13.7 LBS

**PSV-1104-02** 10' X 19" Ply/Wood Replacement Deck WT. 20.83 LBS



**PSV-1106** 5' X 19" Aluminum Board WT. 25.00 LBS

**PSV-1101** 7' X 19" Aluminum Board WT. 30.00 LBS

**PSV-1103** 10' X 19" Aluminum Board WT. 39.00 LBS

**STVA**  
**GUARD RAIL**  
*Posts*



**PSV-530AC**  
 42" W-Style  
 Female Corner Guard  
 Rail Post (Red) 90° Hole  
 (Candy Cane Lock)  
 WT. 7.70 LBS



**PSV-530AF**  
 BJ-Style Female  
 Corner Guard  
 Rail Post (Yellow)  
 90° Hole  
 (Candy Cane Lock)  
 WT. 6.18 LBS



**PSV-530BC**  
 Female Guard  
 Rail Post (Blue)  
 45° Hole  
 (Candy Cane Lock)  
 WT. 7.7 LBS



**PSV-530BF**  
 Female Corner Guard  
 Rail Post 45° Hole  
 (Flip Lock)  
 WT. 6.02 LBS



**PSV-537AN**  
 42" W-Style  
 Rail Post W/ Kicker  
 (Blue) 90° Hole  
 (Candy Cane Lock)  
 WT. 8.30 LBS



**PSV-537AR**  
 42" W-Style  
 Rail Post W/ Kicker  
 (Red) 90° Hole  
 (Candy Cane Lock)  
 WT. 8.30 LBS



**PSV-540A**  
 Male Guard Rail Post  
 W/ 90° Hole  
 (Flip Lock)  
 WT. 5.22 LBS



**PSV-540B**  
 Male Guard Rail Post  
 W/ 45° Hole  
 (Flip Lock)  
 WT. 5.22 LBS



# PUTLOGS



**PSV-750** 8' Putlog (Truss) WT. 27.60 LBS

**PSV-751** 12' Putlog (Truss) WT. 42.20 LBS



**PSV-752** 16' Putlog (Truss) WT. 62.40 LBS

**PSV-755** 22' Putlog (Truss) WT. 86.57 LBS



**PSV-756** 5' Putlog Spreader WT. 24.2 LBS



**PSV-760**

Parallel Putlog Hanger

WT. 4.40 LBS



**PSV-761**

Right Angle Putlog Hanger

WT. 5.00 LBS



**PSV-656A**

Saddle Pin

WT. 2.13 LBS



**PSV-656B**

Saddle Pin

WT. 2.13 LBS



# SCAFFOLD TAGS



**PSV-Tag-Stop**

Stop Tags  
(Package of 25)



**PSV-Tag-OK**

OK (Safe For Use) Tags  
(Package of 25)



**PSV-Tag-Caution**

Caution Tags  
(Package of 25)



**PSV-Tag-Pouch**

Clear Pouch  
(Package of 25)



# STORAGE & SHIPPING Rack & Basket



**PSV-4200**

Stackable Storage Rack

WT. 123.46 LBS



**PSV-4201**

Collapsible Storage Basket

WT. 75.20 LBS

**STVA**  
**SCREW**  
*Jacks*



**PSV-171**  
 1-1/4" Screw Jack  
 W/Swivel Base Plate  
 WT. 14.0 LBS



**PSV-164**  
 1-3/8" Swivel  
 Screw Jack  
 WT. 14.80 LBS



**PSV-140**  
 24" Extension  
 Base Plate  
 WT. 4.20 LBS



**PSV-130**  
 1-3/8" Socket Jack  
 WT. 10.40 LBS



**PSV-130S**  
 1-1/2" Socket Jack  
 WT. 8.20 Lbs



**PSV-134**  
 1-3/8" X 24"  
 Screw Jack  
 W/Base Plate  
 WT. 11.40 LBS



**PSV-131**  
 1-1/4" X 24"  
 Screw Jack  
 W/ Base Plate  
 WT. 10.40 LBS

**STVA**  
**CONCRETE FORMING**  
*Accessories*



**PSV-1350**  
 Forming Turnbuckle  
 Flat Plate  
 WT. 7.40 LBS



**PSV-1351**  
 Forming Turnbuckle  
 Bent Plate  
 WT. 8.00 LBS



**PSV-110**  
 Wedge Bolt  
 WT. 0.20 LBS



**PSV-181**  
 1/2" Coil & Nut Bolt  
 WT. 0.20 LBS



**STVA**  
**HOIST ARMS**  
*& Well Wheels*



**PSV-3001**  
 10" Well Wheel  
 Depth of Well 1"  
 Comes In Zinc or Red  
 WT. 9.60 LBS

**PSV-3002**  
 12" Well Wheel  
 Depth of Well 1"  
 WT. 15.4 LBS

**PSV-3000A**  
 W-Style  
 Hoist Arm  
 WT. 29.85 LBS

**PSV-3000B**  
 S-Style  
 Hoist Arm  
 WT. 29.99 LBS



**STVA**  
**FOLDING**  
*A-Frames*



**PSV-1400** 3' Folding A Frame WT. 22.40 LBS

**PSV-1401** 4' Folding A Frame WT. 32.00 LBS

**PSV-1402HD** 6' Folding A Frame WT. 49.00 LBS

**STVA** **STANCHIONS**



**PSV-535**  
 Guard Rail Stanchion  
 WT. 24.80 LBS



**PSV-538**  
 Guard Rail Stanchion  
 Square Tube  
 WT. 20.60 LBS

**STVA** **MORTAR *Stands***



**PSV-1501** 20" X 30" Mortar Stand WT. 17.00 LBS

**STVA** **VENEER *Jacks***

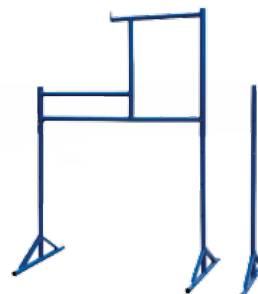

**PSV-470** Veneer Jack Frames WT. 17.20 LBS

**PSV-471** Veneer Jack Legs WT. 8.80 LBS

**STVA** **MORTAR *Tubs***



**PSV-1530**  
 10 Gauge Steel  
 Mortar Tub  
 WT. 173.8 LBS

**PSV-1531**  
 14 Gauge Steel  
 Mortar Tub  
 WT. 117.7 LBS



# MULTI-PURPOSE /Interior Scaffolding



**PSV-2000** Steel Multi-Purpose Unit (Yellow) WT. 150 LBS

**PSV-1999** Steel Multi-Purpose Unit W/Hatch Deck (Yellow) WT. 150 LBS



**PSV-2002** Aluminum Multi-Purpose Unit WT. 90.00 LB



**PSV-2000-5** Multi-Purpose Hatch Deck WT. 31.24 LBS

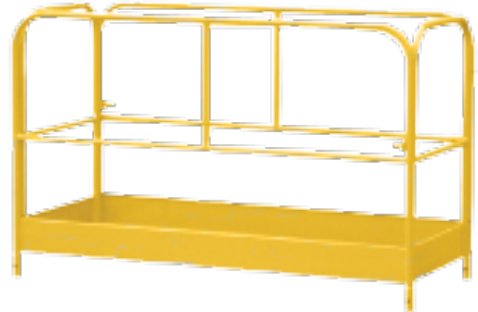

**PSV-2001** Steel Guard Rail Assembly WT. 89 LBS

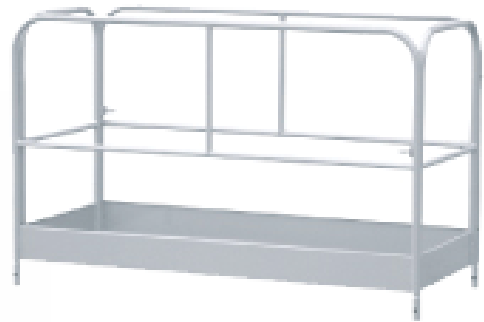

**PSV-2003** Aluminum Guard Rail Assembly WT. 32.6 LBS

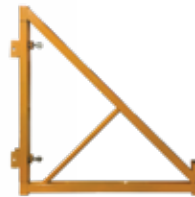

**PSV-208**  
30" Steel Outrigger  
For MPU  
WT. 18.20 LBS



**PSV-207**  
18" Steel Outrigger  
For MPU  
WT. 5.8 LBS



**PSV-151**  
5" Locking Caster  
W/ 1-1/4" Square Stem  
WT. 4.20 LBS



**PSV-141MPU**  
Multi-Purpose 5" X 5"  
Base Plate  
WT. 2.02 LBS

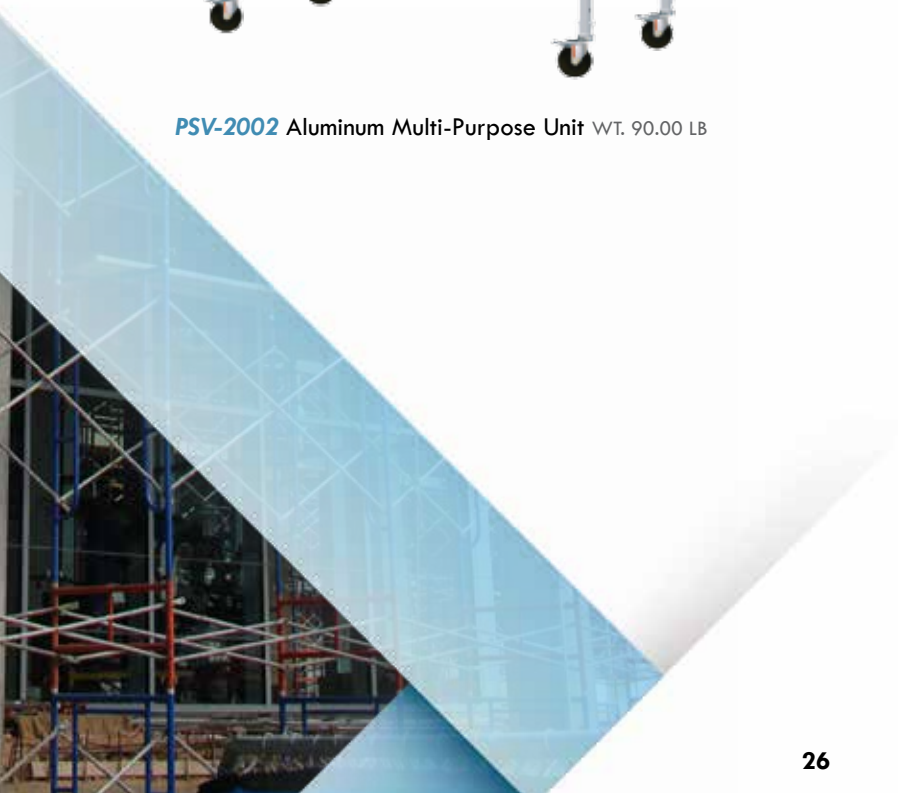

**STVA**  
**TUBE & CLAMP**  
*Scaffold*



**PSV-131N**  
 Base Plate  
 W/ Tube Lock  
 WT. 3.20 LBS



- PSV-909G** 2' Tube W/End Fitting WT. 6.03 LBS
- PSV-910G** 4' Tube W/End Fitting WT. 11.80 LBS
- PSV-911G** 6' Tube W/End Fitting WT. 16.60 LBS
- PSV-912G** 8' Tube W/End Fitting WT. 20.20 LBS
- PSV-913G** 10' Tube W/End Fitting WT. 26.20 LBS
- PSV-914G** 13' Tube W/End Fitting WT. 48.80 LBS
- PSV-916G** 16' Tube W/End Fitting WT. 37.95 LBS
- PSV-915G** 20' Tube W/End Fitting WT. 40.00 LBS
- PSV-938G** 24' Tube W/End Fitting WT. 48.40 LBS

**STVA**  
**SCAFFOLD**  
*Clamps*

All 2" clamps can be ordered with I-Bolt or T-Bolt



**PSV-771**  
 3-1/2" X 2"  
 Swivel Clamp  
 WT. 5.40 LBS



**PSV-772**  
 3-1/2" X 2"  
 Right Angle Clamp  
 WT. 5.94 LBS



**PSV-773**  
 3-1/2" Stud Clamp  
 WT. 4.20 LBS



**PSV-900**  
 2" X 2" Swivel Clamp  
 WT. 3.86 LBS



**PSV-901**  
 Right Angle Clamp  
 WT. 3.22 LBS



**PSV-902**  
 Rigid Beam Clamp  
 WT. 3.20 LBS



**PSV-902S**  
 Swivel Beam Clamp  
 WT. 3.40 LBS



**PSV-904**  
 Half Clamp  
 WT. 1.80 LBS



**PSV-905**  
 2-1/2" X 2"  
 Swivel Clamp  
 WT. 5.40 LBS



**PSV-906**  
 2-1/2" X 2"  
 Right Angle Clamp  
 WT. 5.00 LBS



**PSV-907N**  
 2" Stud Clamp  
 WT. 1.67 LBS



# H.L.10K SHORING Frames

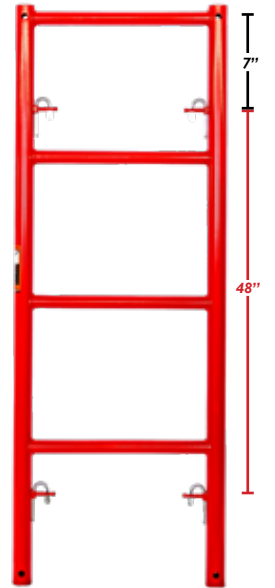
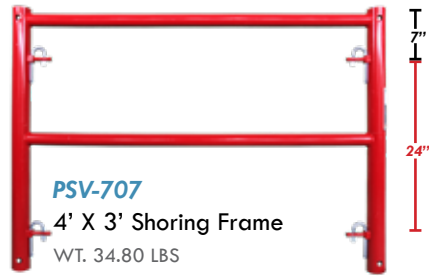
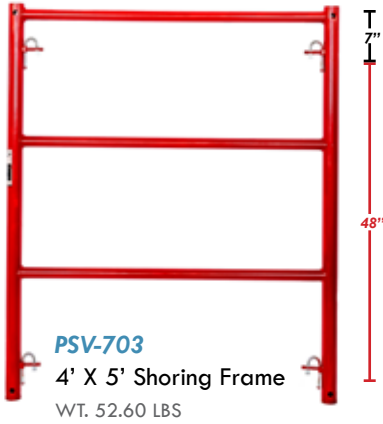
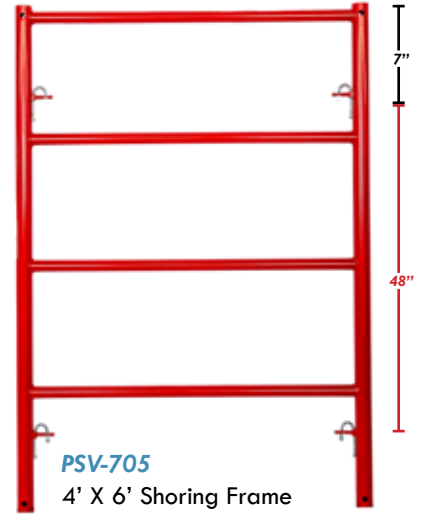

- Uses PSV-102
- Standard Color RED
- First Lock 7" From Top of Frame Leg (13" on 6' Tall Frames)
- Candy Cane Locking System
- 2.375" O.D. Tube Diameter X 0.148" Wall Thickness

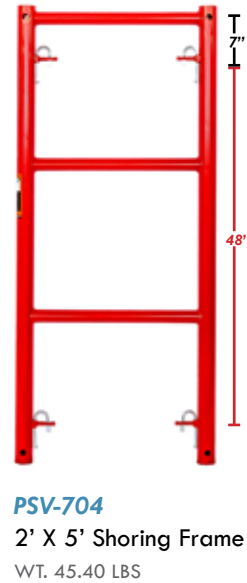
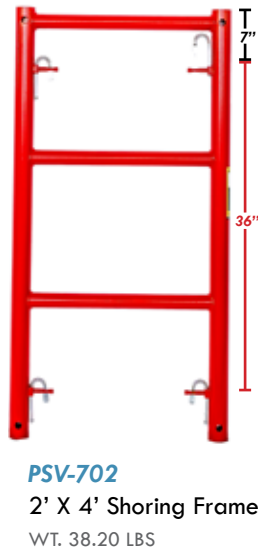



# 25K SHORING Frames

- Uses PSV-55100
- Standard Color RED
- Candy Cane Locking System
- 3" Square Tube Diameter X 3/16" Wall Thickness

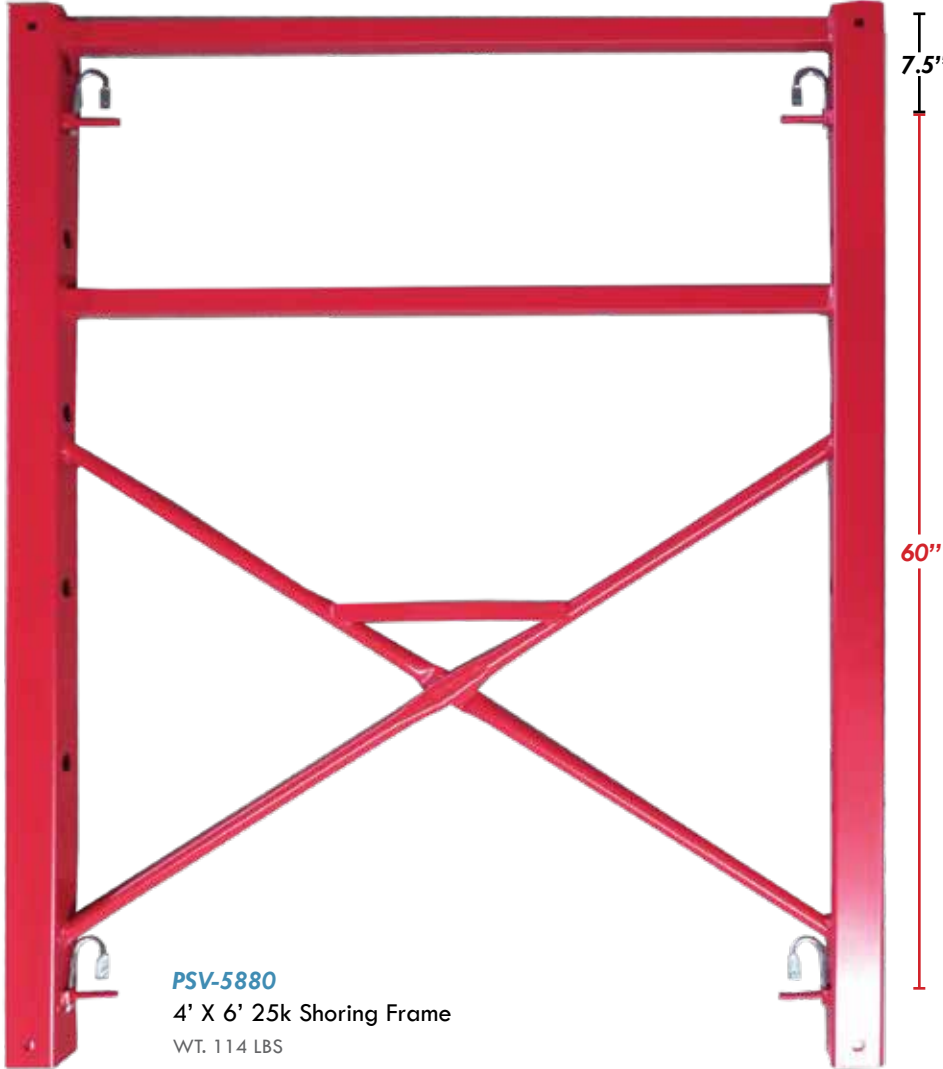
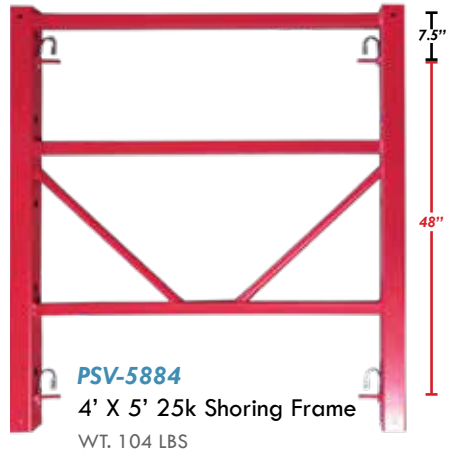
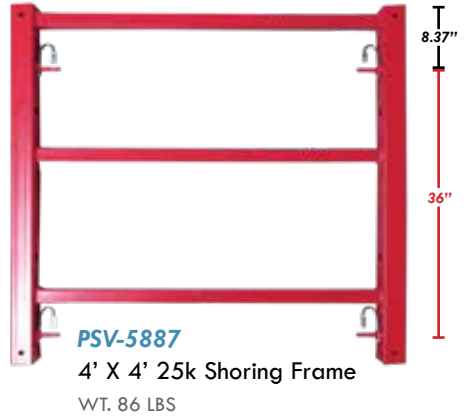

PSV-5142  
25k Shoring Insert  
WT. 4.4 LBS



PSV-55100  
25k Shoring Alignment Pin  
WT. 3.3 LBS



PSV-5200  
25k Solid Bar Shoring Screw Jacks  
WT. 27.19 LBS



PSV-55099  
25k Shoring Adaptor Pin  
WT. 3.1 LBS



PSV-5102  
Nailing Plate For 25k Frame Leg  
WT. 2.31 LBS

**STVA**  
**10-25K SHORING**  
*Accessories*



*Small* 2.4mm



*Medium* 3.8mm



*Large* 4.5mm

**PSV-117B** Large Hitch Pin WT 0.05 LBS

**PSV-117M** Medium Hitch Pin WT 0.04 LBS

**PSV-117S** Small Hitch Pin WT 0.01 LBS



**PSV-908A**

#1 A-Clamp Assembly  
(Steel)

WT. 0.50 LBS



**PSV-908AN**

#1 A-Clamp Assembly (Steel)  
Bolt & Nut

WT. 0.29 LBS

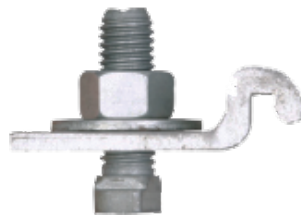

**PSV-908B**

#2 A-Clamp Assembly  
(Aluminum)  
Bolt, Nut & Washer (Steel)

WT. 0.31 LBS



**PSV-908BNW**

#2 A-Clamp Assembly  
Bolt, Nut & Washer (Steel)

WT. 0.18 LBS



**PSV-2611**

#2 C-Clamp W/  
3/4" Opening

WT. 0.35 LBS



**PSV-2611B**

#2 C-Clamp W/ 1" Opening

WT. 0.38 LBS



**PSV-116**

3" X 5/8" Drilled Rivet

WT. 0.34 LBS



**PSV-129**

J-PIN

WT. 0.56 LBS





# 10K NOMINAL RANGE

## Post Shores

2.375" O.D. Post Shore, 1.9" O.D. Staff Post.  
(Available powder coated black or galvanized.)



**PSV-719 (#1)**  
5'9" to 10'3"  
Post Shore  
WT. 39.24 LBS



**PSV-720 (#2)**  
6'6" to 11'  
Post Shore  
W/ Or W/Out U-Head  
WT. 47.72 LBS



**PSV-721 (#3)**  
8'6" to 13'  
Post Shore  
WT. 53.45 LBS



**PSV-722 (#4)**  
10'6" to 16'  
Post Shore  
WT. 63.16 LBS



**PSV-121N**  
Threaded Drop Lock  
WT. 0.24 LBS



# 25K NOMINAL RANGE

## Post Shores

3" O.D. Post Shore, 2.50" O.D. Staff Post.  
(Available powder coated black or galvanized.)



**PSV-724G**  
5'7" to 9'6"  
Galvanized  
25k Post Shore  
WT. 51.71 LBS



**PSV-729G**  
6'6" to 11'6"  
Galvanized  
25k Post Shore  
WT. 61.0 LBS



**PSV-733G**  
10' to 18'  
Galvanized  
25k Post Shore  
WT. 88.4 LBS



*STVA Post Shores now have threaded weld nuts welded on the outer tube. These Threaded Weld Nuts (PSV-121N-03) accept Threaded Drop Locks (PSV-121N) that self support Post Shore structures on your job site, as shown in the example above. PSV-121N Threaded Drop Locks are sold separately.*

**STVA**  
**10-25K SHORING**  
*Accessories*



**PSV-143**  
 7" X 7" Shoring Base Plate  
 For Shoring Jack  
 WT. 6.05 LBS



**PSV-142**  
 7" X 9" Shoring Base Plate  
 For Shoring Jack  
 WT. 7.57 LBS



**PSV-149**  
 7" X 7" Shoring Base Plate  
 For Frame Leg  
 WT. 6.20 LBS



**PSV-156**  
 5" X 8" Shoring J-Head  
 For Shoring Jack  
 WT. 7.60 LBS



**PSV-144**  
 8" X 8" Shoring U-Head  
 For Shoring Jack  
 WT. 12.60 LBS



**PSV-147**  
 8" X 9" Shoring U-Head  
 For Shoring Jack  
 WT. 13.60 LBS



**PSV-157**  
 8" X 10" Shoring U-Head  
 For Shoring Jack  
 WT. 14.00 LBS



**PSV-158**  
 5" X 7" 10k Post Shore  
 U-Head  
 WT. 8.60 LBS



**PSV-5144**  
 25k Post Shore U-Head  
 WT. 10.01 LBS





**STVA**  
**10-25K SHORING**  
*Accessories*



**PSV-126**  
Nailing Plate For  
10k Frame Leg  
WT. 1.21 LBS



**PSV-5103**  
Post Shore Spring Clip  
WT. 0.15 LBS



**PSV-143S**  
6" X 6" 10k Shoring  
Swivel Base Plate  
WT. 4.73 LBS



**PSV-720-03**  
Post Shore Nut  
For 6'-11' Post Shore  
WT. 2.60 LBS



**PSV-191**  
Post Shore Handle  
WT. 1.41 LBS



**PSV-180**  
Reshore Clip  
WT. 0.03 LBS

**STVA**  
**25K SHORING**  
*Accessories*



**PSV-5117**  
 25k Adapter Pin Hitch Pin  
 WT. 0.08 LBS



**PSV-5129**  
 25k Alignment J-Pin  
 WT. 0.77 LBS



**PSV-5160**  
 25k Screw Jack  
 with 8 X 8 U-Head  
 WT. 20 LBS



**PSV-5161**  
 25k Screw Jack with  
 6 X 6 X .500 J-Head  
 WT. 14.64 LBS



**PSV-5162**  
 25k Screw Jack with  
 6 X 6 X .500 U-Head  
 WT. 15.65 LBS

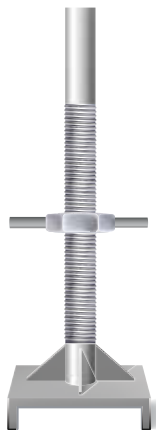

**PSV-5201**  
 25k 8 X 9 Screw Jack  
 with U-Head  
 WT. 35 LBS



**PSV-5950**  
 25k 12" Bar Brace  
 WT. 0.66 LBS



**PSV-5141**  
 25k Frame Extension  
 WT. 21.56 LBS

**STVA**  
**SIDEWALK**  
*Bridging*

- Standard Color DARK BLUE
- Available with Welded Stud or Bolt and Nut
- Clamps Can Be I or T-Bolt



**PSV-780**  
 8' Sidewalk  
 Bridge Leg  
 WT. 58.40 LBS



**PSV-781**  
 10' Sidewalk  
 Bridge Leg  
 WT. 67.80 LBS



**PSV-782**  
 12' Sidewalk  
 Bridge Leg  
 WT. 78.69 LBS



**PSV-783**  
 14' Sidewalk  
 Bridge Leg  
 WT. 89.28 LBS



**PSV-784**  
 16' Sidewalk  
 Bridge Leg  
 WT. 102.67 LBS



**PSV-770**  
 Diagonal Brace  
 WT. 11.79 LBS



**PSV-127S** 2" Sidewalk Nut/Bolt Wt. 0.26 LBS



**PSV-127L** 5-1/2" Sidewalk Nut/Bolt Wt. 0.53 LB



**PSV-790** 1' Horizontal Girt WT. 1.01 LBS

**PSV-791** 2' Horizontal Girt WT. 1.02 LBS

**PSV-810** 3' Horizontal Girt WT. 4.84 LBS

**PSV-792** 4' Horizontal Girt WT. 6.56 LBS

**PSV-797** 5' Horizontal Girt WT. 7.81 LBS

**PSV-793** 6' Horizontal Girt WT. 9.72 LBS

**PSV-796** 7' Horizontal Girt WT. 11.30 LBS

**PSV-794** 8' Horizontal Girt WT. 12.34 LBS

**PSV-795** 10' Horizontal Girt WT. 15.99 LBS



**PSV-775**  
 Large Panel Brace  
 WT. 3.30 LBS



**PSV-776**  
 Small Panel Brace  
 WT. 1.36 LBS



**PSV-774**  
 Head Clip  
 WT. 2.73 LBS

Ask About  
 Lead Times

**BACK ORDER  
 PRODUCTS**

# SHORING EXTENSIONS & Screw Jacks



**PSV-137**  
30" Extension  
TB Jack  
WT. 19.8 LBS



**PSV-138**  
48" Extension  
BX Jack  
WT. 22.2 LBS



**PSV-169**  
20" SX-Style Screw  
Jack W/ 4 1/2" X 14"  
U-Head  
WT. 21.0 LBS



**PSV-178**  
5' Extension Tube  
W/ 8" X 14"  
U-Head  
WT. 50.6 LBS

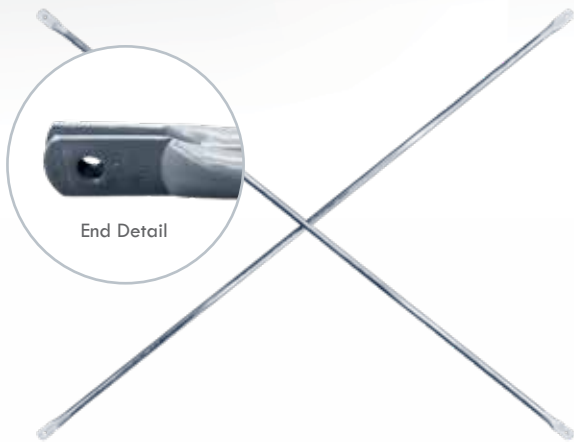

End Detail

## STVA TUBE Cross Braces

- PSV-310** 8' X 4' Tube Cross Brace WT. 12.80 LBS
- PSV-315** 8' X 3' Tube Cross Brace WT. 12.20 LBS
- PSV-318** 5' X 3' Tube Cross Brace WT. 8.60 LBS
- PSV-322** 8' X 2.5' Tube Cross Brace WT. 12.03 LBS
- PSV-323** 8' X 1' Tube Cross Brace WT. 11.33 LBS
- PSV-324** 6' X 3' Tube Cross Brace WT. 9.59 LBS
- PSV-327** 6' X 3' X 4' Tube Cross Brace WT. 10.50 LBS
- PSV-328** 5' X 1' Tube Cross Brace WT. 7.40 LBS

## MISC. SHORING Accessories



**PSV-145**  
8" X 8" Shoring  
Base Plate  
WT. 7.96 LBS



**PSV-179-02**  
Cast Steel Nut For  
Hi-Lite 30" DD Screw Jack  
WT. 2.60 LBS



**PSV-179-03**  
Cast Steel Base Plate For  
Hi-Lite 30" Dd Screw Jack  
Hook On Angle Iron  
WT. 4.40 LBS

Ask About  
Lead Times

**BACK ORDER  
PRODUCTS**

**STVA**  
**SX SHORING**  
 Frames

- Uses PSV-102B Connector
- Standard Color DARK BLUE
- Base Frame 2.375" O.D. X 0.156" Wall Thickness
- Extension Frame 1.9" O.D. X 0.19" Wall Thickness
- 5' Lock Spacing
- V-Style Slide Locks

**BACK ORDER PRODUCTS**

Ask About Lead Times

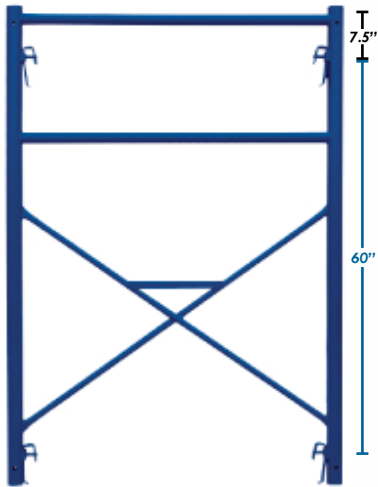

**PSV-880**  
 4' X 6' SX Base Frame  
 WT. 65.25 LBS

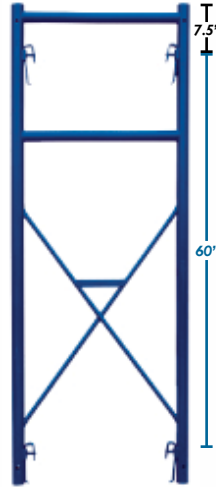

**PSV-881**  
 2' X 6' SX Base Frame  
 WT. 54.38 LBS

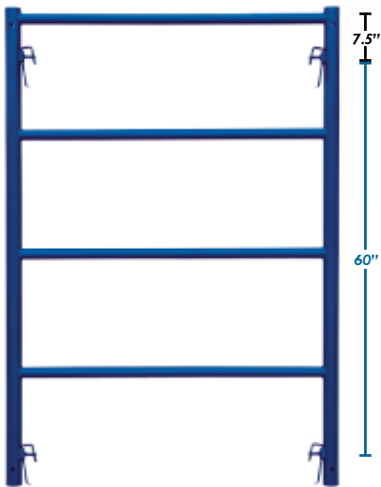

**PSV-885**  
 4' X 6' SX Base Frame  
 (Ladder Style)  
 WT. 66.35 LBS

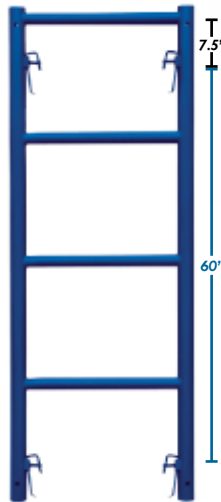

**PSV-886**  
 2' X 6' SX Base Frame  
 (Ladder Style)  
 WT. 57.73 LBS



**PSV-718 (#0)**  
 3'6" to 6'  
 Post Shore  
 WT. 26.49 LBS

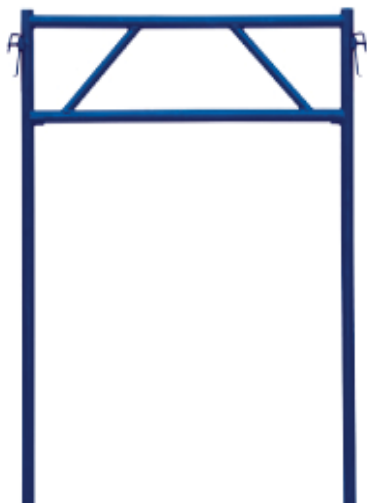

**PSV-890**  
 4' X 5'4" SX  
 Extension Frame  
 WT. 52.03 LBS



**PSV-891**  
 2' X 5'4" SX  
 Extension Frame  
 WT. 47.19 LBS



**PSV-5099**  
 SX Adapter Pin  
 Zinc Plated  
 WT. 1.10 LBS

**STVA**  
**MISCELLANEOUS**  
*Products*



**PSV-918**  
8' Top Rail For  
Internal Stair Unit  
WT. 16.40 LBS



**PSV-921B**  
8' X 6'4" Internal Stair  
Unit W/ Hand Rails  
WT. 123.53 LBS

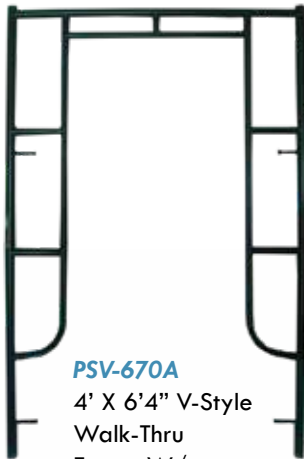

**PSV-670A**  
4' X 6'4" V-Style  
Walk-Thru  
Frame W/  
Drop Lock  
WT. 43.00 LBS

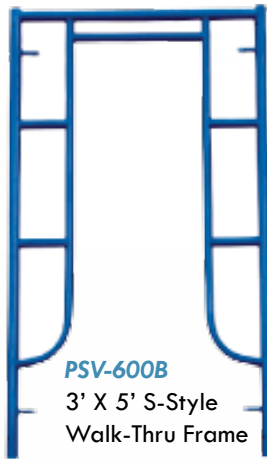

**PSV-600B**  
3' X 5' S-Style  
Walk-Thru Frame  
WT. 32.56 LBS

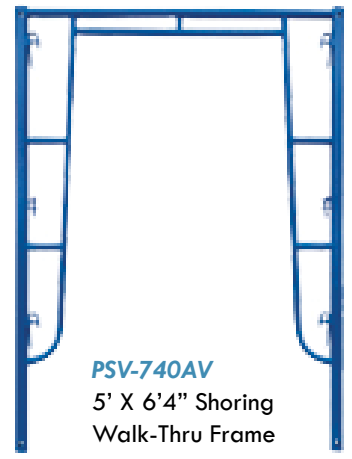

**PSV-740AV**  
5' X 6'4" Shoring  
Walk-Thru Frame  
WT. 71.20 LBS



**PSV-1500**  
36" X 30" Mortar Stand  
WT. 19.54 LBS

Ask About  
Lead Times

**BACK ORDER  
PRODUCTS**

**BACK ORDER  
PRODUCTS**

Ask About  
Lead Times

**STVA**  
**MISCELLANEOUS**  
*Products*



**PSV-1301**  
Timber Bracing Clamp  
WT. 2.71 LBS

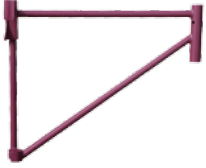

**PSV-209**  
S-Style 24" Tube  
Side Bracket  
WT. 7.40 LBS

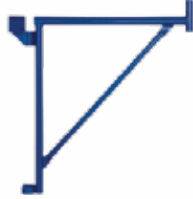

**PSV-220A** W-Style  
**PSV-220B** S-Style  
30" Saddle Tube Side Bracket  
WT. 13.80 LBS

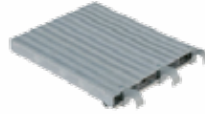

**PSV-1109**  
8' X 19" Aluminum Board  
WT. 33.70 LBS



**PSV-1144106** 10' X 6.5" A-Beam WT. 43 LBS

**PSV-114412** 12' X 6.5" A-Beam WT. 49 LBS

**PSV-114414** 14' X 6.5" A-Beam WT. 57 LBS

**PSV-114416** 16' X 6.5" A-Beam WT. 66 LBS

**PSV-114418** 18' X 6.5" A-Beam WT. 74 LBS

**PSV-114421** 21' X 6.5" A-Beam WT. 86 LBS



**PSV-167N**  
1-3/8" Leveling Jack  
W/No Base Plate  
WT. 9.50 LBS



**PSV-173**  
1-5/8" Rigid Base Plate  
W/4" Stem And 5" Plate  
WT. 2.0 LBS



**PSV-146B**  
5" X 5" S-Style Swivel  
Base Plate 45° Angle  
WT. 4.05 LBS

**STVA** **ANGLE IRON** *Cross Braces*

**PSV-356** 7' X 45" Angle Iron Cross Brace WT. 17.67 LBS

**PSV-357** 7' X 42" Angle Iron Cross Brace WT. 17.47 LBS

**PSV-358** 7' X 17-1/2" Angle Iron Cross Brace WT. 12.61 LBS

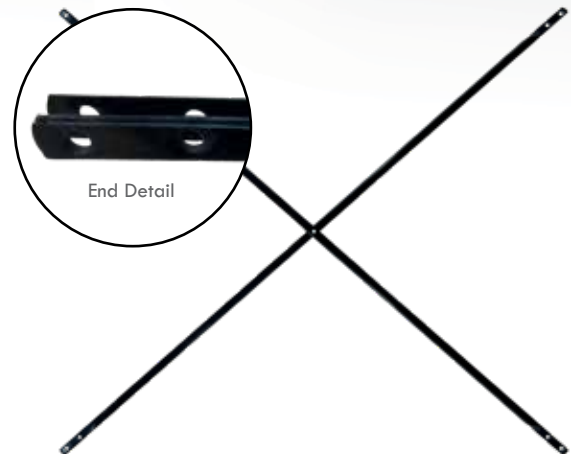



# **SYSTEM**

*Scaffold Equipment*





# TABLE OF CONTENTS

Ring Lock Standards with Spigot .....	42
Ring Lock Board Brackets .....	42
Ring Lock Ledgers .....	43
Ring Lock Truss Ledgers .....	44
Ring Lock Lattice Girder .....	44
Ring Lock Double Ledgers .....	44
Ring Lock Vertical/Diagonals/Bay Brace .....	45
Ring Lock Swivel Clamp Horizontal Diagonal Brace .....	45
Ring Lock Ladders & Brackets .....	46
System Equipment Screw Jacks .....	46
System Equipment Starter Collars .....	46
System Equipment Accessories .....	47-48
Cup Lock Verticals/Standards .....	49
Cup Lock Horizontal Ledgers .....	50
Cup Lock Double Ledgers .....	50
Cup Lock Trussed Ledger .....	51
Cup Lock Bay Brace/Face Brace .....	51
Cup Lock Board Brackets .....	51
Cup Lock Ladders & Brackets .....	52



**RING** Lock



**CUP** Lock



# STVA RING LOCK Standards with Spigots

The Ring Lock System can accommodate up to eight connections of combined ledgers and braces. Each of these connections can safely carry a load of 5,000 lbs. (11.12kN)

However, the total sum of the ledger loads MUST NOT exceed the recommended leg load for any given bracing situation.

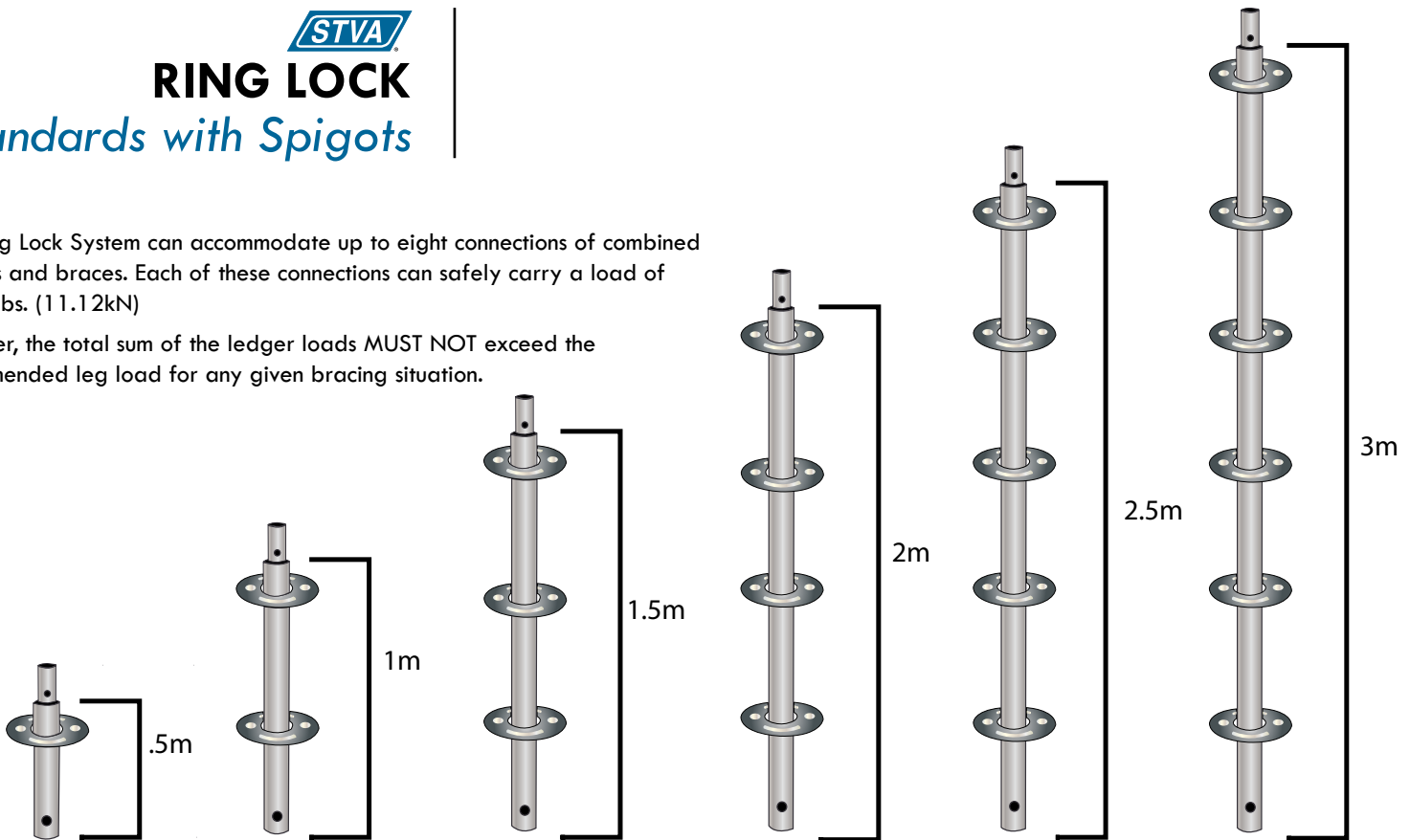

STVA Product No.	Product Description	Weight	Dimension
PSV-RL-9105	0.5m Standard - Vertical W/Spigot 1-Ring	6.49 LBS	1' 7-11/16"
PSV-RL-9110	1.0m Standard - Vertical W/Spigot 2-Ring	11.44 LBS	3' 3-3/8"
PSV-RL-9115	1.5m Standard - Vertical W/Spigot 3-Ring	16.41 LBS	4' 11-1/16"
PSV-RL-9120	2.0m Standard - Vertical W/Spigot 4-Ring	21.36 LBS	6' 6-47/64"
PSV-RL-9125	2.5m Standard - Vertical W/Spigot 5-Ring	26.33 LBS	8' 2-27/64"
PSV-RL-9130	3.0m Standard - Vertical W/Spigot 6-Ring	31.5 LBS	9' 10-7/64"

# STVA RING LOCK Board Brackets

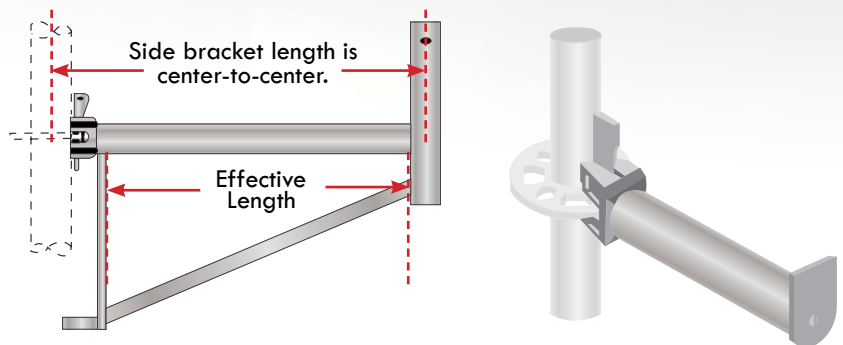

STVA Product No.	Product Description	Weight	Dimension	Effective Length
PSV-RL-9601N	1 Board Side Bracket - 12"	9.61 LBS	12.60"	9.47"
PSV-RL-9602	2 Board Side Bracket W/Spigot-24"	14.27 LBS	25.59"	21.81"
PSV-RL-9603	3 Board Side Bracket W/Spigot-34"	18.67 LBS	34.65"	30.81"

**STVA**  
**RING LOCK**  
 Ledgers

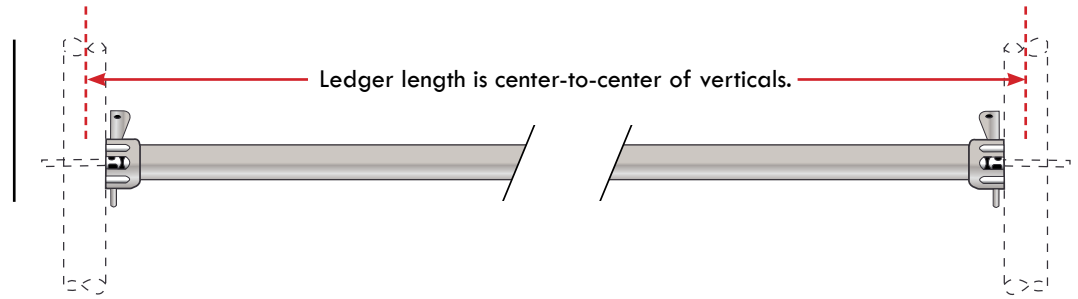

STVA Product No.	Product Description	Weight	Dimension
<i>PSV-RL-9210</i>	1' Single Ledger (0.305m)	2.6 LBS	12"
<i>PSV-RL-9216</i>	1' 6" Single Ledger (0.457m)	5.5 LBS	1' 6"
<i>PSV-RL-9220</i>	2' Single Ledger (0.609m)	6 LBS	2'
<i>PSV-RL-9222</i>	2' 2" Single Ledger (0.660m)	6.4 LBS	2' 2"
<i>PSV-RL-9224</i>	2' 4" Single Ledger (0.711m)	7.30 LBS	2' 4"
<i>PSV-RL-9226</i>	2' 6" Single Ledger (0.762m)	7.5 LBS	2' 6"
<i>PSV-RL-9230</i>	3' Single Ledger (0.914m)	8.93 LBS	3'
<i>PSV-RL-9236</i>	3' 6" Single Ledger (1.066m)	10.14 LBS	3' 6"
<i>PSV-RL-92310</i>	3' 10" Single Ledger (1.168m)	11 LBS	3' 10"
<i>PSV-RL-9240</i>	4' Single Ledger (1.219m)	11.35 LBS	4'
<i>PSV-RL-9243</i>	4' 3" Single Ledger (1.295m)	12.61 LBS	4' 3"
<i>PSV-RL-92411</i>	4' 11" Single Ledger (1.498m)	14.3 LBS	4' 11"
<i>PSV-RL-9250</i>	5' Single Ledger (1.524m)	13.77 LBS	5'
<i>PSV-RL-9252</i>	5' 2" Single Ledger (1.572m)	14.94 LBS	5' 2"
<i>PSV-RL-9254</i>	5' 4" Single Ledger (1.625m)	15.36 LBS	5' 4"
<i>PSV-RL-9260</i>	6' Single Ledger (1.828m)	16.19 LBS	6'
<i>PSV-RL-9269</i>	6' 9-1/2" Single Ledger (2.057m)	18.03 LBS	6' 9-1/2"
<i>PSV-RL-9270</i>	7' Single Ledger (2.133m)	18.61 LBS	7'
<i>PSV-RL-9280</i>	8' Single Ledger (2.438m)	21.03 LBS	8'
<i>PSV-RL-9285</i>	8' 5" Single Ledger (2.565m)	23.19 LBS	8' 5"
<i>PSV-RL-9286</i>	8' 6" Single Ledger (2.590m)	22.24 LBS	8' 6"
<i>PSV-RL-9290</i>	9' Single Ledger (2.743m)	23.98 LBS	9'
<i>PSV-RL-92100</i>	10' Single Ledger (3.048m)	26.99 LBS	10'
<i>PSV-RL-92101</i>	10' 1" Single Ledger (3.073m)	26.15 LBS	10' 1"
<i>PSV-RL-9612</i>	2 Board Bracket Ledger For Side Bracket (0.649m)	5.72 LBS	25.59"
<i>PSV-RL-9613</i>	3 Board Bracket Ledger For Side Bracket (0.879m)	7.72 LBS	34.64"

**STVA**  
**RING LOCK**  
*Truss Ledgers*

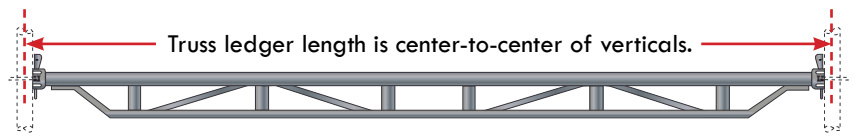

STVA Product No.	Product Description	Weight	Dimension
<a href="#">PSV-RL-9505</a>	5' Truss Ledger (1.524m)	22.55 LBS	5'
<a href="#">PSV-RL-9506</a>	6' Truss Ledger (1.828m)	27.25 LBS	6'
<a href="#">PSV-RL-9507</a>	7' Truss Ledger (2.133m)	30.51 LBS	7'
<a href="#">PSV-RL-9508</a>	8' Truss Ledger (2.438m)	39.99 LBS	8'
<a href="#">PSV-RL-9509</a>	9' Truss Ledger (2.743m)	43.02 LBS	9'
<a href="#">PSV-RL-9510</a>	10' Truss Ledger (3.048m)	46.04 LBS	10'
<a href="#">PSV-RL-9512</a>	12' Truss Ledger (3.657m)	55.97 LBS	12'
<a href="#">PSV-RL-9514</a>	14' Truss Ledger (4.267m)	65.27 LBS	14'
<a href="#">PSV-RL-9516</a>	16' Truss Ledger (4.876m)	74.47 LBS	16'
<a href="#">PSV-RL-9520</a>	20' Truss Ledger (6.096m)	94.05 LBS	20'

**STVA**  
**RING LOCK**  
*Lock Lattice Girders*

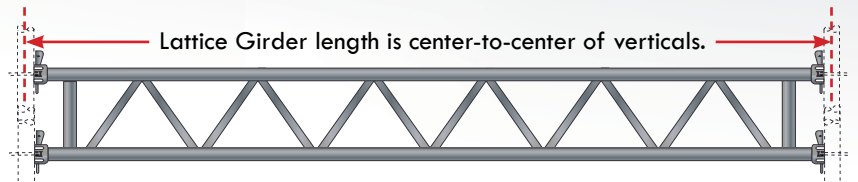

STVA Product No.	Product Description	Weight	Dimension
<a href="#">PSV-RL-9807</a>	7' Lattice Girder (2.133m)	61.8 LBS	7'
<a href="#">PSV-RL-9810</a>	10' Lattice Girder (3.048m)	83.9 LBS	10'
<a href="#">PSV-RL-9814</a>	14' Lattice Girder (4.627m)	111.8 LBS	14'
<a href="#">PSV-RL-9816</a>	16' Lattice Girder (4.876m)	125.5 LBS	16'
<a href="#">PSV-RL-9818</a>	18' Lattice Girder (5.486m)	139.3 LBS	18'
<a href="#">PSV-RL-9820</a>	20' Lattice Girder (6.096m)	153.1 LBS	20'
<a href="#">PSV-RL-9821</a>	21' Lattice Girder (6.400m)	154.1 LBS	21'
<a href="#">PSV-RL-9828</a>	28' Lattice Girder (8.543m)	219.3 LBS	28'

**STVA**  
**RING LOCK**  
*Double Ledgers*

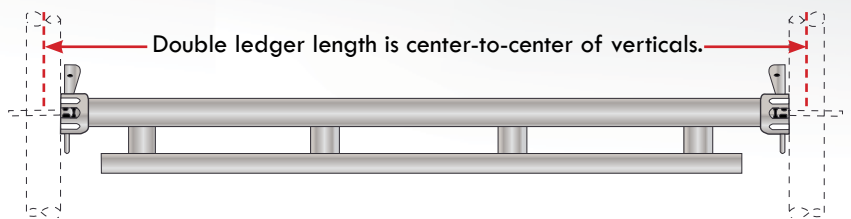

STVA Product No.	Product Description	Weight	Dimension
<a href="#">PSV-RL-9505N</a>	5' Double Ledger (1.524m)	27.5 LBS	5'
<a href="#">PSV-RL-9506N</a>	6' Double Ledger (1.828m)	31.2 LBS	6'
<a href="#">PSV-RL-9507N</a>	7' Double Ledger (2.133m)	34.5 LBS	7'
<a href="#">PSV-RL-9508N</a>	8' Double Ledger (2.438m)	40.7 LBS	8'
<a href="#">PSV-RL-9509N</a>	9' Double Ledger (2.743m)	46.5 LBS	9'
<a href="#">PSV-RL-9510N</a>	10' Double Ledger (3.048m)	51.7 LBS	10'

# STVA RING LOCK Vertical/Diagonals/Bay Brace



STVA Product No.	Product Description	Weight	Effective Working Dims	'A' Dimension
PSV-RL-9316	1' Vertical Diagonals/Bay Brace	14.82 LBS	39.37"BW X 59.10"HT (1m X 1.50m)	67.3"
PSV-RL-93246	2' 4" Vertical Diagonals/Bay Brace	17.09 LBS	28"BW X 78.74"HT (0.711m X 2m)	81.47"
PSV-RL-9336	3' Vertical Diagonals/Bay Brace	17.53 LBS	36"BW X 78.74"HT (0.914m X 2m)	83.88"
PSV-RL-93366	3' 6" Vertical Diagonals/Bay Brace	17.89 LBS	42" X 78.74"HT (1.066m X 2m)	86.13"
PSV-RL-9346	4' Vertical Diagonals/Bay Brace	13.91 LBS	48"BW X 78.74"HT (1.22m X 2m)	88.73"
PSV-RL-93436	4' 3" Vertical Diagonals/Bay Brace	18.48 LBS	51"BW X 78.74"HT (1.295m X 2m)	90.15"
PSV-RL-934116	4' 11" Vertical Diagonals/Bay Brace	19.14 LBS	59"BW X 78.74"HT (1.500m X 2m)	94.34"
PSV-RL-9356	5' Vertical Diagonals/Bay Brace	24.35 LBS	60"BW X 78.74"HT (1.524m X 2m)	96.61"
PSV-RL-93526	5' 2" Vertical Diagonals/Bay Brace	19.40 LBS	62"BW X 78.74"HT (1.574m X 2m)	96"
PSV-RL-9366	6' Vertical Diagonals/Bay Brace	0.90 LBS	72"BW X 78.74"HT (1.828m X 2m)	103.79"
PSV-RL-93696	6' 9" Vertical Diagonals/Bay Brace	21.31 LBS	81"BW X 78.74"HT (2.057m X 2m)	107.98"
PSV-RL-9376	7' Vertical Diagonals/Bay Brace	27.57 LBS	84"BW X 78.74"HT (2.133m X 2m)	110.07"
PSV-RL-9386	8' Vertical Diagonals/Bay Brace	29.41 LBS	96"BW X 78.74"HT (2.438m X 2m)	120.51"
PSV-RL-93866	8' 6" Vertical Diagonals/Bay Brace	23.76 LBS	102"BW X 78.74"HT (2.590m X 2m)	123.32"
PSV-RL-9396	9' Vertical Diagonals/Bay Brace	23.34 LBS	108"BW X 78.74"HT (2.74m X 2m)	128"
PSV-RL-93106	10' Vertical Diagonals/Bay Brace	33.40 LBS	120"BW X 78.74"HT (3.048m X 2m)	137.66"

## STVA RING LOCK Swivel Clamp Horizontal Diagonal Brace



STVA Product No.	Product Description	Weight	'A' Dimension
PSV-RL-9446	4' X 6' 6" Bay Swivel Clamp Brace	18.19 LBS	92"
PSV-RL-9456	5' X 6' 6" Bay Swivel Clamp Brace	19.25 LBS	99"
PSV-RL-9466	6' X 6' 6" Bay Swivel Clamp Brace	20.33 LBS	106.15"
PSV-RL-9475	7' X 5' Bay Swivel Clamp Brace	19.88 LBS	103-1/4"
PSV-RL-9476	7' X 6' 6" Bay Swivel Clamp Brace	21.67 LBS	115"
PSV-RL-9477	7' X 7' Bay Swivel Clamp Brace	22.26 LBS	108-3/4"
PSV-RL-9478	7' X 8' Bay Swivel Clamp Brace	23.58 LBS	127-1/2"
PSV-RL-9486	8' X 6' 6" Bay Swivel Clamp Brace	22.99 LBS	123.69"
PSV-RL-94866	8' 6" X 6' 6" Bay Swivel Clamp Brace	23.65 LBS	128"
PSV-RL-9488	8' X 8' Bay Swivel Clamp Brace	24.82 LBS	140"
PSV-RL-9496	9' X 6' 6" Bay Swivel Clamp Brace	24.44 LBS	133.32"
PSV-RL-94106	10' X 6' 6" Bay Swivel Clamp Brace	25.94 LBS	143.12"

**STVA**  
**RING LOCK**  
*Ladder & Brackets*



**PSV-RL-990717**  
 Ladder Bracket  
 (17" Wide)  
 WT. 6.64 LBS



STVA Product No.	Product Description	Weight	Dimension
<b>PSV-RL-960317</b>	3' Ring Lock Galvanized Ladder (Wide)	11.44 LBS	17" C/C OF LEG
<b>PSV-RL-960517</b>	5' Ring Lock Galvanized Ladder (Wide)	18.45 LBS	17" C/C OF LEG
<b>PSV-RL-960617</b>	6' Ring Lock Galvanized Ladder (Wide)	21.95 LBS	17" C/C OF LEG
<b>PSV-RL-961017</b>	10' Ring Lock Galvanized Ladder (Wide)	35.57 LBS	17" C/C OF LEG

**STVA**  
**SYSTEM EQUIPMENT**  
*Screw Jacks*



**Swivel Screw Jack Disclaimer:** Swivel Screw Jacks should be anchored to the structure or restrained. Anchors, bolts, or restraints must be able to hold 4 times the shear force that will be applied to the slope. If the angle will exceed 45 degrees, consult a professional engineer before erecting your scaffold structure. STVA recommends that you always consult a professional engineer before designing or erecting any scaffold structure.

STVA Product No.	Product Description	Weight	Dimension
<b>PSV-9903</b>	(15/21) Hollow Screw Jack W/Base Plate	9.3 LBS	15" MAX EXT. / 21" OAL
<b>PSV-9923</b>	(24/30) Hollow Screw Jack W/Base Plate	11.1 LBS	24" MAX EXT. / 30" OAL
<b>PSV-9904</b>	(15/21) Hollow Screw Jack W/Swivel Base Plate	12.1 LBS	15" MAX EXT. / 21" OAL
<b>PSV-9924</b>	(24/30) Hollow Screw Jack W/Swivel Base Plate	14.1 LBS	24" MAX EXT. / 30" OAL

**STVA**  
**SYSTEM EQUIPMENT**  
*Starter Collars*

- PSV-RL-9901** 9" Starter Collar 3.125 LBS
- PSV-RL-99013** 13" Starter Collar 4.35 LBS
- PSV-RL-9917** 17.5" Starter Collar 5.58 LBS



**STVA**  
**SYSTEM EQUIPMENT**  
*Accessories*

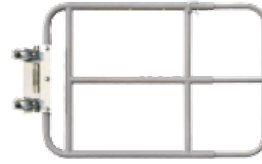

**PSV-RL-9800**  
 3' to 5' Expandable Access Gate (Galvanized) 36"-60"  
 WT. 24.42 LBS



**PSV-RL-9100**  
 Rosette (Forged)  
 WT. 0.99 LBS



**PSV-RL-9905N**  
 Spigot For Standard/Verticals  
 WT. 1.84 LBS



**PSV-RL-9908**  
 Rosette Half Clamp  
 WT. 2.99 LBS



**PSV-RL-9950**  
 12" X 3" Locking Caster  
 WT. 45.1 LBS



**PSV-RL-9912**  
 Swivel Adapter Wedge Coupler  
 WT. 3.52 LBS



**PSV-RL-9913**  
 Ridge Adapter Wedge Coupler  
 WT. 3.12 LBS



**PSV-RL-9914**  
 Spigot Adapter Clamp 8.27"  
 WT. 1.41 LBS

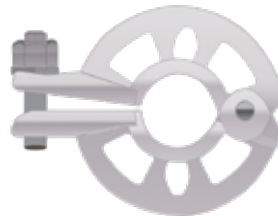

**PSV-RL-9916**  
 Clampable Rosette  
 WT. 2.4 LBS



**PSV-RL-9802**  
 30" Swivel Clamp Davit Arm/Tube & Clamp  
 WT. 26.62 LBS



**PSV-RL-9909**  
 12" Ring Lock Caster Adapter  
 WT. 8.51 LBS



- PSV-RL-6240** 4' Galvanized Toe Board WT. 5.08 LBS
- PSV-RL-6250** 5' Galvanized Toe Board WT. 6.09 LBS
- PSV-RL-6270** 7' Galvanized Toe Board WT. 8.14 LBS
- PSV-RL-6280** 8' Galvanized Toe Board WT. 9.15 LBS
- PSV-RL-6290** 9' Galvanized Toe Board WT. 10.1 LBS
- PSV-RL-6200** 10' Galvanized Toe Board WT. 11.2 LBS

**STVA**  
**SYSTEM EQUIPMENT**  
*Accessories*



**PSV-RL-9766R** 10 Step Right Stair Stringer WT. 41.7 LBS

**PSV-RL-9766L** 10 Step Left Stair Stringer WT. 41.7 LBS



**PSV-RL-9866R** 11 Step Right Stair Stringer WT. 44.3 LBS

**PSV-RL-9866L** 11 Step Left Stair Stringer WT. 44.3 LBS



**PSV-RL-9910**  
 Ring Lock Guard Rail Post  
 (Crazy Leg)  
 WT. 17.2 LBS



**PSV-RL-9730** 30" X 9" Stair Tread (Used W/3'6" Ledger) WT. 11.7 LBS

**PSV-RL-9736** 36" X 9" Stair Tread (Used W/4' Ledger) WT. 13.8 LBS

**PSV-RL-9744** 44" X 9" Stair Tread (Used W/5' Ledger) WT. 16.6 LBS



**PSV-RL-9779**  
 System Stair Unit  
 W/Stair Tread  
 WT. 287 LBS



**PSV-RL-9919** 7' Top Rail For Ring Lock Internal Stair Unit (Hdg) WT. 17.34 LBS



**PSV-RL-9911**  
 23" Safety Vertical For  
 Hanging Ring System  
 WT. 7.79 LBS



**STVA**  
**CUP LOCK**  
*Verticals/Standards*

The Cup System can accommodate up to four connections of combined ledgers and braces. Each of these connections can safely carry a load of 5,000 lbs. (11.12kN)

However, the total sum of the ledger loads **MUST NOT** exceed the recommended leg load for given bracing situation.

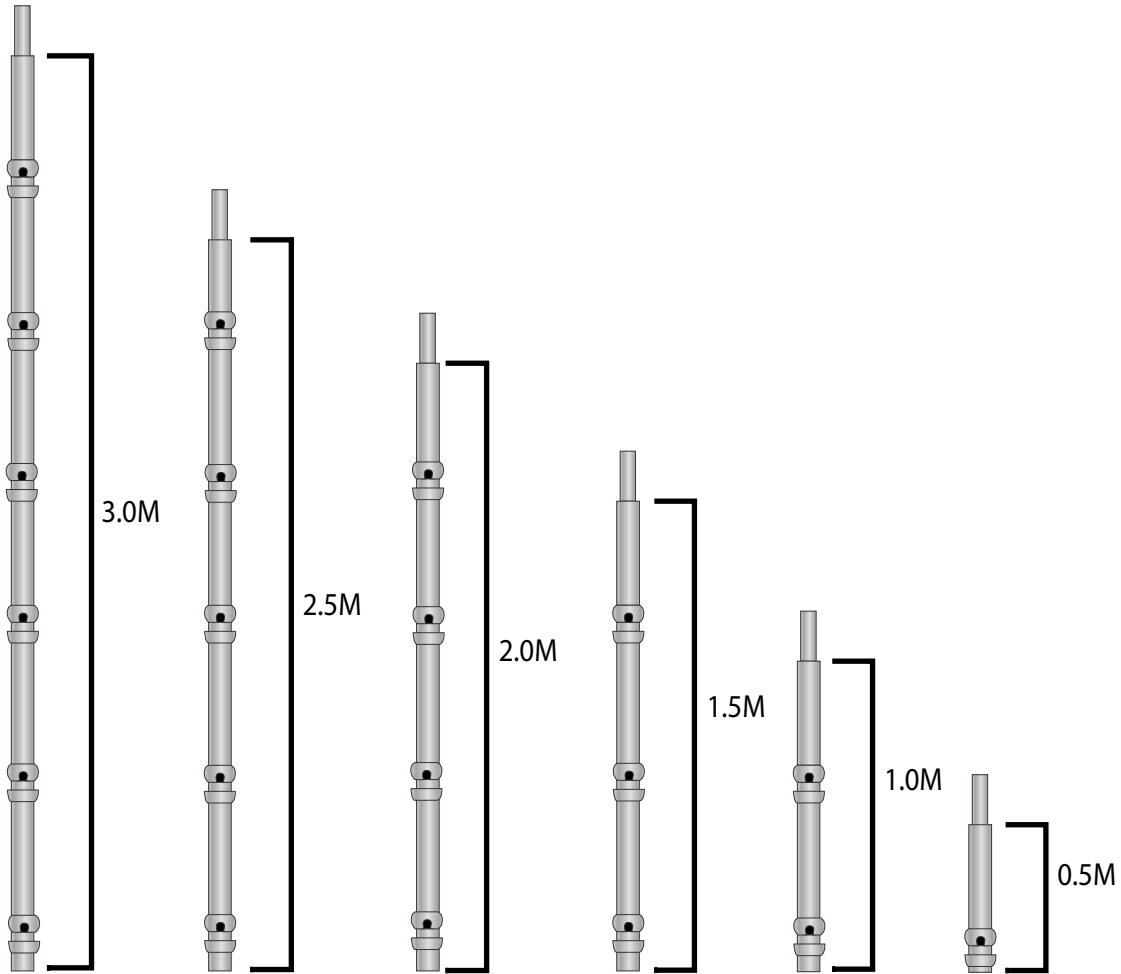

STVA Product No.	Product Description	Weight	Dimension
<a href="#">PSV-CL-8105</a>	Cup 0.5m Vertical W/Spigot 1-Cup	5.61 LBS	1' 7-11/16"
<a href="#">PSV-CL-8110</a>	Cup 1.0m Vertical W/Spigot 2-Cup	11.17 LBS	3' 3-3/8"
<a href="#">PSV-CL-8115</a>	Cup 1.5m Vertical W/Spigot 3-Cup	16.76 LBS	4' 11-1/16"
<a href="#">PSV-CL-8120</a>	Cup 2.0m Vertical W/Spigot 4-Cup	22.33 LBS	6' 6-47/64"
<a href="#">PSV-CL-8125</a>	Cup 2.5m Vertical W/Spigot 5-Cup	27.91 LBS	8' 2-27/64"
<a href="#">PSV-CL-8130</a>	Cup 3.0m Vertical W/Spigot 6-Cup	33.48 LBS	9' 10-7/64"

**STVA**  
**CUP LOCK**  
*Horizontal Ledgers*

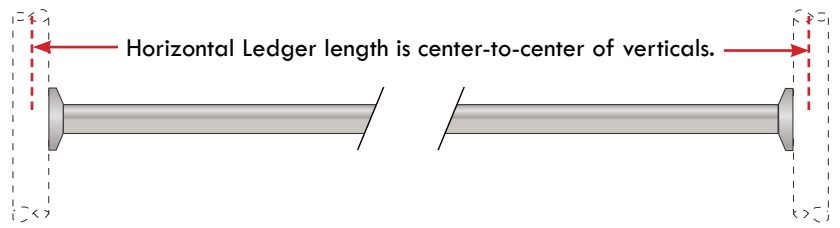

STVA Product No.	Product Description	Weight	Dimension
<i>PSV-CL-82110</i>	Cup 2 Board Bracket Ledger	5.08 LBS	1' 10-1/4"
<i>PSV-CL-8227</i>	Cup 3 Board Bracket Ledger	6.88 LBS	2' 7"
<i>PSV-CL-82060</i>	.60m Cup Ledger (1' 11-5/8")	7.0 LBS	1' 11-5/8"
<i>PSV-CL-82061</i>	2' Cup Ledger	7.2 LBS	2'
<i>PSV-CL-82090</i>	.90m Cup Ledger (2' 11-7/16")	9.0 LBS	2' 11-7/16"
<i>PSV-CL-8230</i>	3' Cup Ledger	7.89 LBS	3'
<i>PSV-CL-8236</i>	3'-6" Cup Ledger	9.10 LBS	3' 6"
<i>PSV-CL-8240</i>	4' Cup Ledger	10.31 LBS	4'
<i>PSV-CL-82125</i>	1.25m Cup Ledger (4' 1-7/32")	11 LBS	4' 1-7/32"
<i>PSV-CL-82150</i>	1.50m Cup Ledger (4' 11-1/16")	14 LBS	4' 11-1/16"
<i>PSV-CL-8250</i>	5' Cup Ledger 1	2.73 LBS	5'
<i>PSV-CL-82180</i>	1.80m Cup Ledger (5' 10-55/64")	16 LBS	5' 10-55/64"
<i>PSV-CL-8260</i>	6' Cup Ledger	15.15 LBS	6'
<i>PSV-CL-8270</i>	7' Cup Ledger	17.57 LBS	7'
<i>PSV-CL-8280</i>	8' Cup Ledger	19.99 LBS	8'
<i>PSV-CL-82250</i>	2.5m Cup Ledger (8' 2-27/64")	22 LBS	8' 2-27/64"
<i>PSV-CL-8290</i>	9' Cup Ledger	22.41 LBS	9'
<i>PSV-CL-82100</i>	10' Cup Ledger	24.83 LBS	10'

**STVA**  
**CUP LOCK**  
*Double Ledgers*

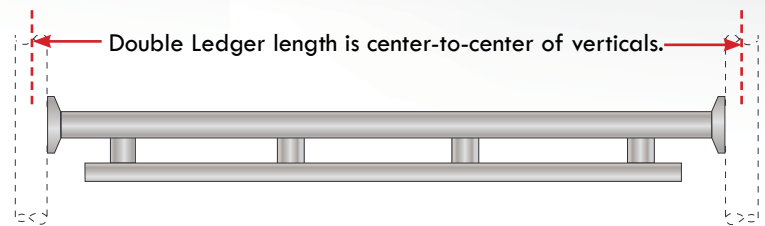

STVA Product No.	Product Description	Weight	Dimension
<i>PSV-CL-8505N</i>	5' Cup Double Ledger	22.0 LBS	5'
<i>PSV-CL-8506N</i>	6' Cup Double Ledger	27.0 LBS	6'
<i>PSV-CL-8507N</i>	7' Cup Double Ledger	31.5 LBS	7'
<i>PSV-CL-8508N</i>	8' Cup Double Ledger	36.0 LBS	8'
<i>PSV-CL-8509N</i>	9' Cup Double Ledger	40.5 LBS	9'
<i>PSV-CL-8510N</i>	10' Cup Double Ledger	45.01 LBS	10'

**STVA**  
**CUP LOCK**  
*Trussed Ledger*

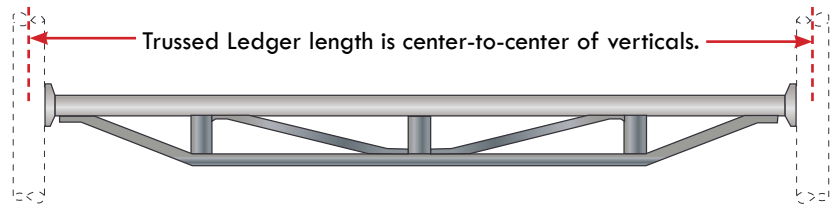

STVA Product No.	Product Description	Weight	Dimension
<a href="#">PSV-CL-8505</a>	5' Cup Truss Ledger	20.48 LBS	5'
<a href="#">PSV-CL-8506</a>	6' Cup Truss Ledger	24.97 LBS	6'
<a href="#">PSV-CL-8507</a>	7' Cup Truss Ledger	29.48 LBS	7'
<a href="#">PSV-CL-8508</a>	8' Cup Truss Ledger	37.5 LBS	8'
<a href="#">PSV-CL-8514</a>	14' Cup Truss Ledger	65.1 LBS	14'
<a href="#">PSV-CL-8516</a>	16' Cup Truss Ledger	90.2 LBS	16'

**STVA**  
**CUP LOCK**  
*Bay Brace/Face Brace*



STVA Product No.	Product Description	Weight	Dimension
<a href="#">PSV-CL-8346</a>	4' X 6' 6" Cup Bay/Face Brace	16.2 LBS	4' X 6' 6"
<a href="#">PSV-CL-8356</a>	5' X 6' 6" Cup Bay/Face Brace	17.3 LBS	5' X 6' 6"
<a href="#">PSV-CL-8376</a>	7' X 6' 6" Cup Bay/Face Brace	25.71 LBS	7' X 6' 6"
<a href="#">PSV-CL-8386</a>	8' X 6' 6" Cup Bay/Face Brace	25.1 LBS	8' X 6' 6"
<a href="#">PSV-CL-83106</a>	10' X 6' 6" Cup Bay/Face Brace	31.48 LBS	10' X 6' 6"

**STVA**  
**CUP LOCK**  
*Board Brackets*

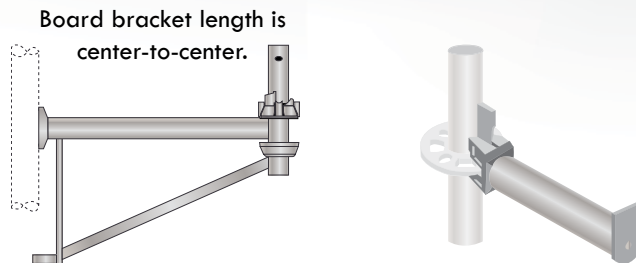

[PSV-CL-8905N](#)  
 Cantilever Extension Adapter  
 5.0 lbs

STVA Product No.	Product Description	Weight	Dimension
<a href="#">PSV-CL-8601N</a>	1 Board Cup Bracket	3.5 LBS	11.4"
<a href="#">PSV-CL-8602</a>	2 Board Cup Bracket	12.8 LBS	22.2"
<a href="#">PSV-CL-8603</a>	3 Board Cup Bracket	17.3 LBS	31.3"
<a href="#">PSV-CL-82110</a>	Cup 2 Board Bracket Ledger	5.08 LBS	1' 10-1/4"
<a href="#">PSV-CL-8227</a>	Cup 3 Board Bracket Ledger	6.88 LBS	2' 7"

**STVA**  
**CUP LOCK**  
*Ladders & Brackets*



STVA Product No.	Product Description	Weight	Dimension
<i>PSV-CL-8604</i>	3' Cup Lock Galvanized Ladder (Wide)	14.10 LBS	14" C/C OF LEG
<i>PSV-CL-8605</i>	5' Cup Lock Galvanized Ladder (Wide)	22.31 LBS	14" C/C OF LEG
<i>PSV-CL-8610</i>	10' Cup Lock Galvanized Ladder (Wide)	42.24 LBS	14" C/C OF LEG

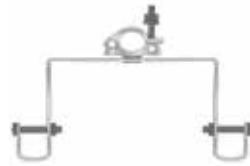

***PSV-CL-8907***  
 Cup Lock Ladder Bracket  
 (14" Wide)  
 WT. 6.09 LBS

**STVA**  
**NOTES**

---



---



---



---



---



---



---



---



---



---



---

---

---

---

---

---

---

---

---

---

---

---

---

---

---

---

---



# SAFETY RULES & Regulations

Following are some common sense rules designed to promote safety in the use of steel scaffolding. These rules are illustrative and suggestive only, and are intended to deal only with some of the many practices and conditions encountered in the use of scaffolding. The rules do not purport to be all-inclusive or to supplant or replace other additional safety and precautionary measures to cover usual or unusual conditions. They are not intended to conflict with, or supersede, any state, local, federal statute or regulations; the user should make reference to such provisions (See Rule II.)

POST THESE SCAFFOLDING SAFETY RULES in a conspicuous place and be sure that all persons who erect, dismantle or use scaffolding are aware of them.

FOLLOW ALL STATE, LOCAL, AND FEDERAL CODES, ORDINANCES & REGULATIONS pertaining to scaffolding.

INSPECT ALL EQUIPMENT BEFORE USING-Never use any equipment that is damaged or deteriorated in any way.

KEEP ALL EQUIPMENT IN GOOD REPAIR. Avoid using rusted equipment-the strength of rusted equipment is not known.

INSPECT ERECTED SCAFFOLDS REGULARLY to be sure that they are maintained in safe condition.

CONSULT YOUR SCAFFOLDING SUPPLIER WHEN IN DOUBT-scaffolding is his business, NEVER TAKE CHANCES.

- A. PROVIDE ADEQUATE SILL for scaffold posts and use base plates.
- B. USE ADJUSTING SCREWS instead of blocking to adjust to uneven grade conditions.
- C. PLUMB AND LEVEL ALL SCAFFOLDS as the erection proceeds. Do not force braces to fit-level the scaffold until proper fit can be made easily.
- D. FASTEN ALL BRACES SECURELY.
- E. DO NOT CLIMB CROSS BRACES. An access (climbing) ladder, access steps, frame designed to be climbed or equivalent safe access to the scaffold shall be used.
- F. ON WALL SCAFFOLDS PLACE AND MAINTAIN ANCHORS securely between structure and scaffold at least every 30' of length and 25' of height.
- G. WHEN SCAFFOLDS ARE TO BE PARTIALLY OR FULLY ENCLOSED, specific precautions must be taken to assure frequency and adequacy of ties attaching the scaffolding to the building due to increased load conditions resulting from effects of wind and weather. The scaffolding components to which the ties are attached must also be checked for additional loads.
- H. FREE STANDING SCAFFOLD TOWERS MUST BE RESTRAINED FROM TIPPING by guying or other means.
- I. EQUIP ALL PLANKED OR STAGED AREAS with proper guardrails, midrails and toeboards along all open sides and ends of scaffold platforms.
- J. POWER LINE NEAR SCAFFOLDS are dangerous-use caution and consult the power service company for advice
- K. DO NOT USE ladders of makeshift devices on top of scaffolds to increase the height.
- L. DO NOT OVERLOAD SCAFFOLDS.
- M. PLANKING:
  1. Use only lumber that is properly inspected and graded as scaffold plank.
  2. Planking shall have at least 12" of overlap and extend 6" beyond center of support, or be cleated at both ends to prevent sliding off supporters.
  3. Fabricated scaffold planks and platforms unless cleated or restrained by hooks shall extend over their end supporters not less than 6" nor more than 12".
  4. Secure plank to scaffold when necessary.
- N. FOR ROLLING SCAFFOLD THE FOLLOWING ADDITIONAL RULES APPLY:
  1. DO NOT RIDE ROLLING SCAFFOLDS
  2. SECURE OR REMOVE ALL MATERIALS AND EQUIPMENT from platform before moving scaffold.
  3. CASTER'S BRAKES MUST BE APPLIED at all times when scaffolds are not being moved.
  4. CASTERS WITH PLAIN STEMS shall be attached to the panel or adjustment screw by pins or other suitable means.
  5. DO NOT ATTEMPT TO MOVE A ROLLING SCAFFOLD WITHOUT SUFFICIENT HELP-watch out for holes in floor and overhead obstructions.
  6. DO NOT EXTEND ADJUSTING SCREWS ON ROLLING SCAFFOLD MORE THAN 12".
  7. USE HORIZONTAL DIAGONAL BRACING near the bottom and at 20' intervals measured from the rolling surface.
  8. DO NOT USE BRACKETS ON ROLLING SCAFFOLDS without consideration of overturning effect.
  9. THE WORKING PLATFORM HEIGHT OF A ROLLING SCAFFOLD must not exceed four times the smallest base dimension unless guyed or otherwise stabilized.
- O. For "PUTLOGS" and "TRUSSES" the following additional rules apply.
  1. DO NOT CANTILEVER OR EXTEND PUTLOGS/TRUSSES as side brackets without thorough considerations for loads to be applied.
  2. PUTLOGS/TRUSSES SHOULD EXTEND AT LEAST 6" beyond point of support.
  3. PLACE PROPER BRACING BETWEEN PUTLOG/TRUSSES when the span of putlog/truss is more than 12".
- P. ALL BRACKETS shall be seated correctly with side brackets parallel to the frames and end brackets at 90 degrees to the frame. Brackets shall not be bent or twisted from normal position. Brackets (except mobile brackets designed to carry material) are to be used as work platforms only and shall not be used for storage of material or equipment.
- Q. ALL SCAFFOLD ACCESSORIES shall be used and installed in accordance with the manufacturers recommended procedure. Accessories shall not be altered in the field. Scaffold, frames and their components, manufactured by different companies shall not be intermixed.



**S**AFETY **T**ESTING **V**ALUE **A**SSURANCE

Scaffold • Shoring • Tube & Clamp • System

MANUFACTURING & SALES

19902 Hufsmith-Kohrville Rd • Tomball, TX 77375

877-890-8490 | 281-890-6150 (FAX)

[www.STVAonline.com](http://www.STVAonline.com) | e-mail: [order@stvaonline.com](mailto:order@stvaonline.com)

